

FBH056/057

Installation Instruction 安装说明

FBH056 - M001a



Type Number 型号	Voltage/Frequency 电压/功率		Lamp Holder 灯座		A (mm)	B (mm)	C (mm)	D (mm)	Class 电器等级
FBH056 IXPL-C10W/2P I	220V / 50Hz	PL-C10W/2P	G24d-1	0.99	140	208	100	130	Class I
FBH057 IXPL-C13W/2P I	220V / 50Hz	PL-C13W/2P	G24d-1	1.08	170	223	100	155~160	Class I
FBH057 IXPL-C18W/2P I	220V / 50Hz	PL-C18W/2P	G24d-2	1.15	170	223	100	155~160	Class I
FBH056 IXPL-C10W/2P I FG	220V / 50Hz	PL-C10W/2P	G24d-1	1.29	140	208	100	130	Class I
FBH057 IXPL-C13W/2P I FG	220V / 50Hz	PL-C13W/2P	G24d-1	1.48	170	223	100	155~160	Class I
FBH057 IXPL-C18W/2P I FG	220V / 50Hz	PL-C18W/2P	G24d-2	1.55	170	223	100	155~160	Class I

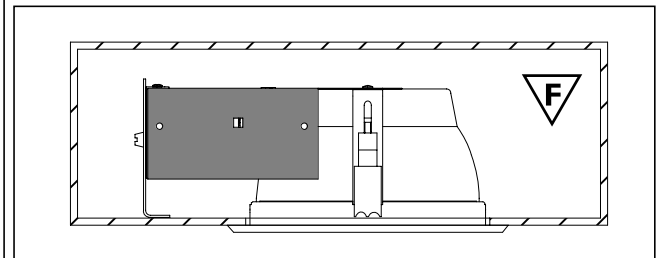
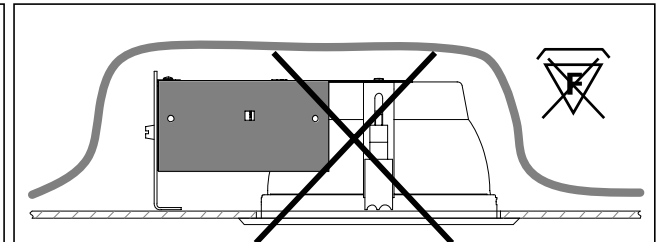
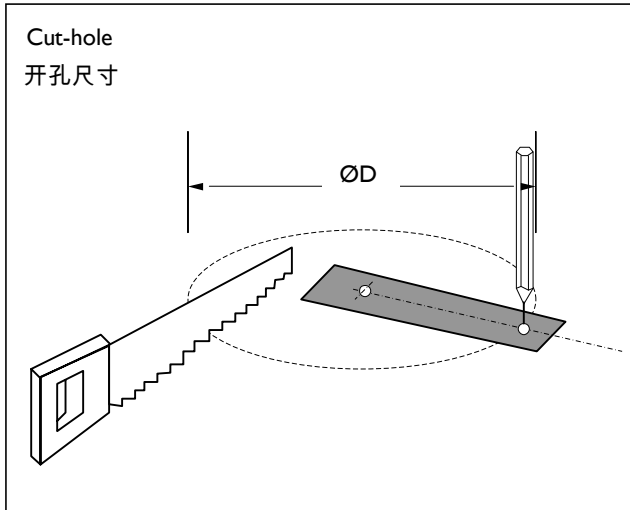
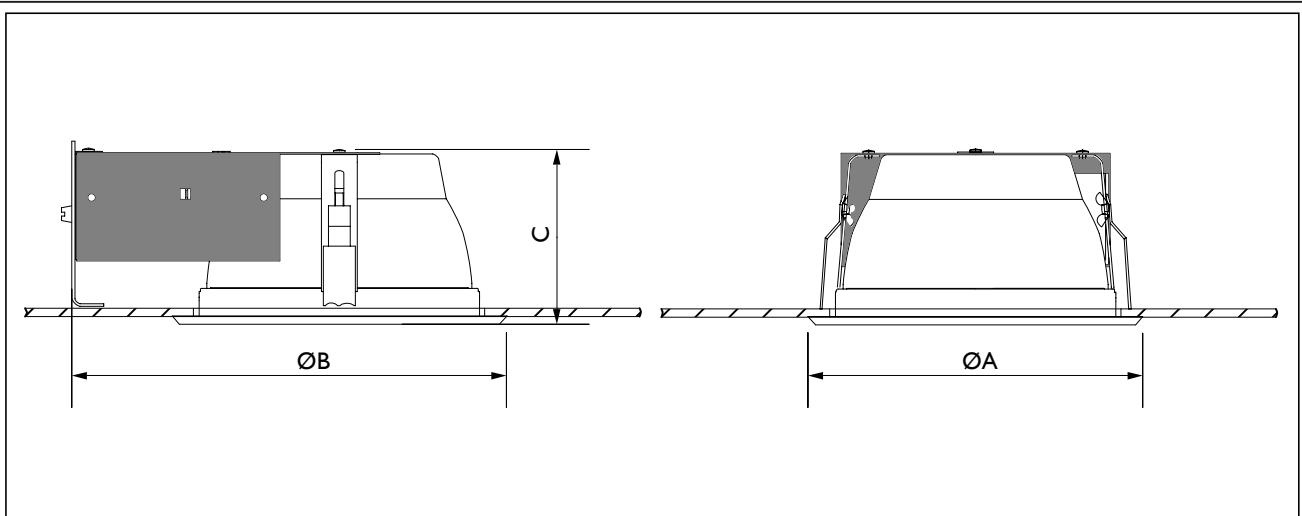

-
- The luminaire shall be installed by a qualified electrician and wired in accordance with the latest IEE electrical regulations or the national requirements.
光源应由有资格的电工安装，接线要符合IEE电气标准或国家标准。
 - The luminaire shall, under no circumstance, be covered with thermal insulation matting or similar material.
灯具不适合被隔热或类似材料覆盖。

