

PHILIPS ADVANCE

Metal Halide Lamp Ballast

Catalog Number 71A5037P
For 35/39W M130
60 Hz R-HPF
Status: Active

DIMENSIONS AND DATA

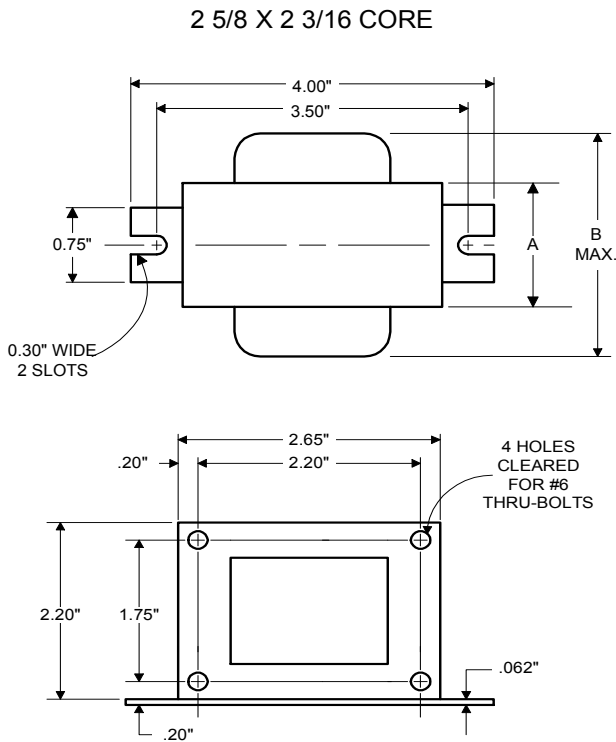

INPUT VOLTS	277				
CIRCUIT TYPE	R-HPF				
POWER FACTOR (min)	90%				
REGULATION					
Line Volts	±5%				
Lamp Watts	±10%				
LINE CURRENT (Amps)					
Operating.....	0.18				
Open Circuit.....	0.52				
Starting.....	0.30				
UL TEMPERATURE RATINGS					
Insulation Class	H(180°C)				
Coil Temperature Code	1029	A			
MIN. AMBIENT STARTING TEMP.	-20°F or -30°C				
NOM. OPEN CIRCUIT VOLTAGE	277				
INPUT VOLTAGE AT LAMP DROPOUT.....	190				
INPUT WATTS	48				
RECOMMENDED FUSE (Amps).....	2				
CORE and COIL					
Dimension (A)	0.80				
Dimension (B)	1.90				
Weight (lbs.)	1.8				
Lead Lengths	12"				
CAPACITOR REQUIREMENT					
Microfarads	5.0				
Volts (min.)	280				
Fault Current Withstand (amps)					
60 Hz TEST PROCEDURES (Refer to Advance Test Procedure for HID Ballasts - Form 1270)					
High Potential Test (Volts)					
1 minute	2000				
2 seconds	2500				
Open Circuit Voltage Test (Volts)	260-290				
Short-Circuit Current Test (Amps)					
Secondary Current	0.55-0.85				
Input Current.....	0.14-0.20	-	-	-	-

Capacitor: 7C050L30RA

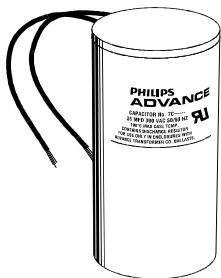

Capacitance: 5
Dia/Oval Dim: 1.25
Height: 2.25
Temp Rating: 105°C

Wiring Diagram:

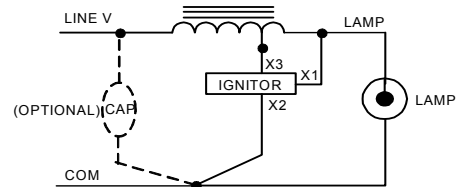
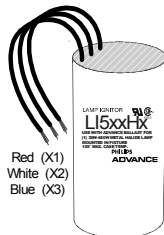

Fig. G

Ordering Information

Ignitor: LI533-H4



Red (X1)
White (X2)
Blue (X3)

Ballast to Lamp Distance (BTL) = 7 feet
Temp Rating: 105°C

Order Suffix

Description

Data is based upon tests performed by Philips Lighting Electronic N.A. in a controlled environment and representative of relative performance. Actual performance can vary depending on operating conditions. Specifications are subject to change without notice.

Philips Lighting Electronic N.A.

10275 West Higgins Road · Rosemont, IL 60018 · Tel:800-322-2086 Fax:888-432-1882
Customer Support/ Technical Service:800-372-3331 · OEM Support: 866-915-5886

08/23/13