

Track RCS350/ZRS350

Installation Instruction 安装说明

IEC
60570

GB
13961



Type NO. 型号	Mounting 安装方式	1Phase Vol 1相电压	3Phase Vol 3相电压	Frequency 频率	Max Current 最大	Figure 外型	L(mm)	kg	IP 防护等级
RCS350 3C L1000 WH	Surface	220~240V	380V~415V	50/60Hz	16A	A	1000	1.2	IP20
RCS350 3C L2000 WH	Surface	220~240V	380V~415V	50/60Hz	16A	A	2000	2.4	IP20
RCS350 3C L3000 WH	Surface	220~240V	380V~415V	50/60Hz	16A	A	3000	3.6	IP20
ZRS350 3C TCP WH T COUPLER	Surface	220~240V	380V~415V	50/60Hz	16A	E		0.2	IP20
ZRS350 3C CPX WH X COUPLER	Surface	220~240V	380V~415V	50/60Hz	16A	F		0.14	IP20
ZRS350 3C CCP WH L COUPLER	Surface	220~240V	380V~415V	50/60Hz	16A	D		0.14	IP20
ZRS350 3C EPS WH SUPPLY	Surface	220~240V	380V~415V	50/60Hz	16A	B		0.07	IP20
ZRS350 3C CPS WH SUPPLY CENTRAL	Surface	220~240V	380V~415V	50/60Hz	16A	C		0.27	IP20

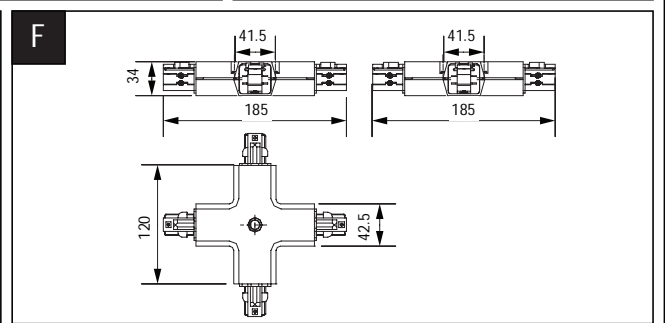
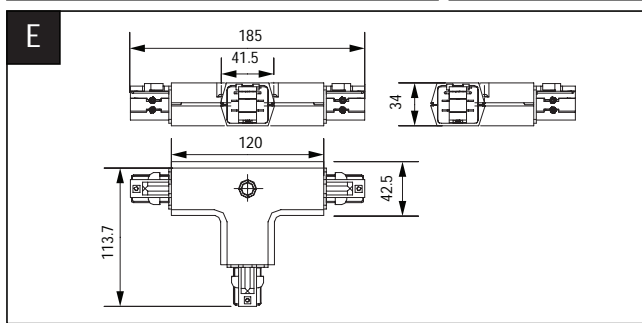
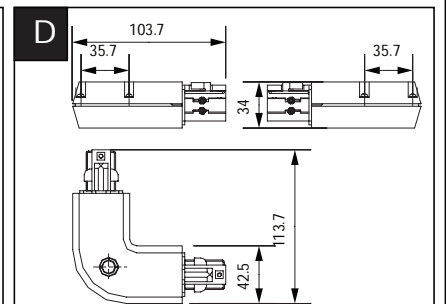
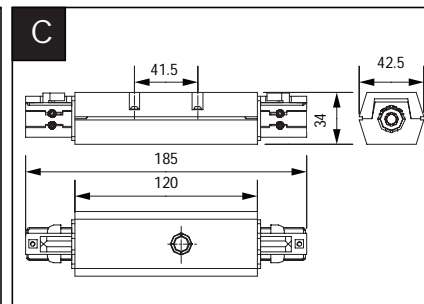
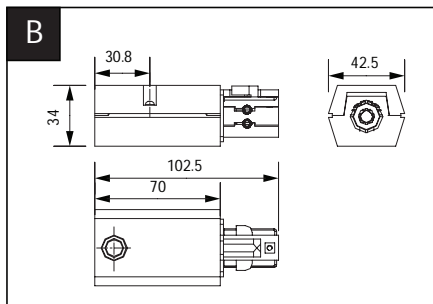
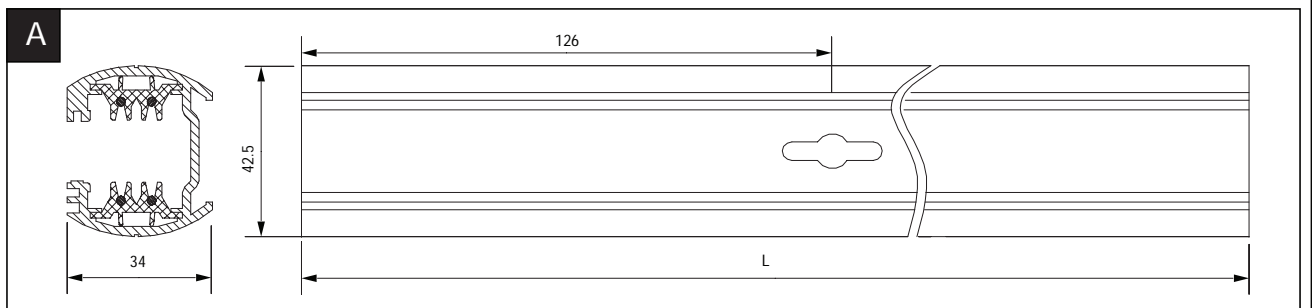

1. Ensure that the luminaire is consistent with the track system in electric, machine and temperature when mounting and using.
安装和使用前, 要保证灯具和轨道系统连接之间电器、机械、热的相容性。
2. The track system is only used to the track projector luminaire of Philips.
此轨道系统仅使用于飞利浦的轨道投射灯。

Philips Lighting Luminaires (Shanghai) Co., Ltd.
Address: No. 2688, Huyi Road, Jiading, Shanghai, China
Postalcode: 201801

飞利浦灯具(上海)有限公司
地址: 中国上海市嘉定区马陆镇沪宜公路2688号
邮编: 201801

PHILIPS

