

Tunnel Lighting

SGX320

Mounting instruction 安装说明

4441 000 62122



IEC
60598

GB
7000

ta
35°

IP65

IK05



Type Number 产品型号	Lamp 光源	Voltage/Frequency 电压/频率	Glass 玻璃	Weight 重量(kg)	Reflector 反射器
SGX320	SON-T 100W	220V/50Hz	FG (平面)	12.7	T-POT/A/S
	SON-T 150W	220V/50Hz		13.7	T-POT/A/S
	SON-T 250W	220V/50Hz		14.7	T-POT/A/S
		230V/50Hz 240V/50Hz		14.7	A
	SON-T 400W	220V/50Hz		17	T-POT/A/S
		230V/50Hz			S

100W

150/250/400W

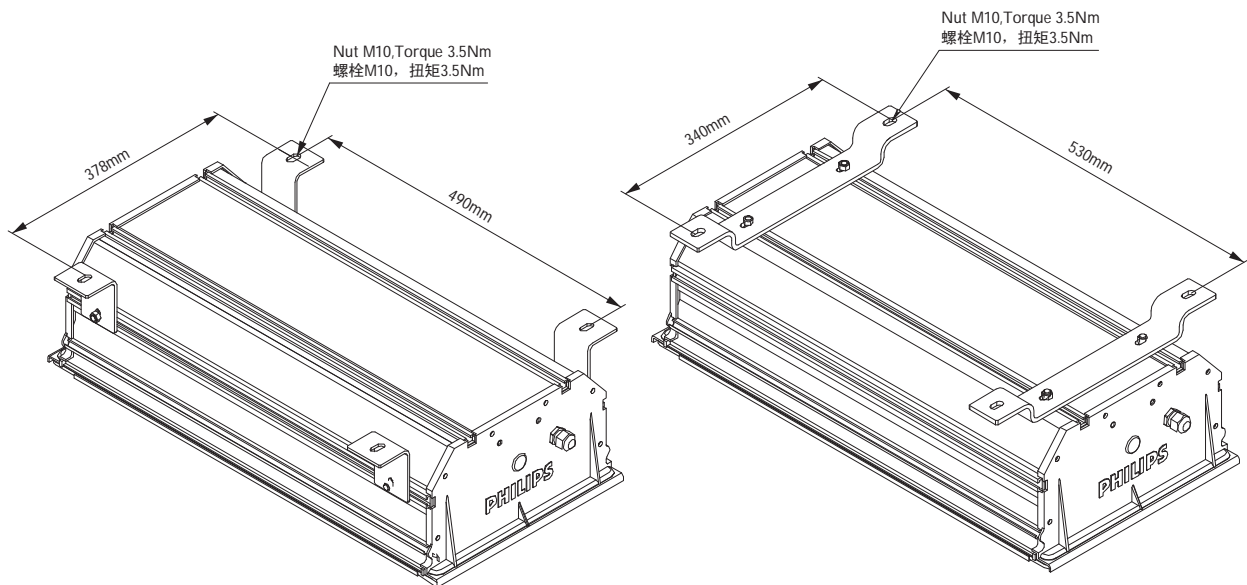
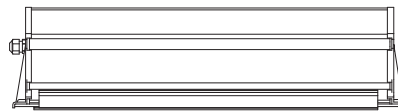
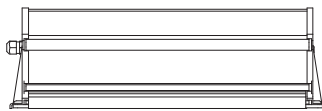
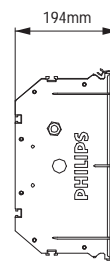
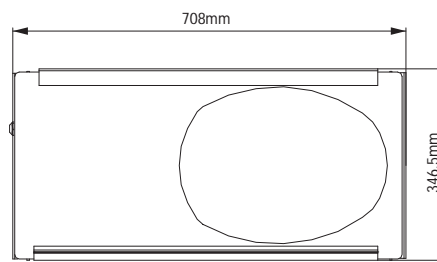
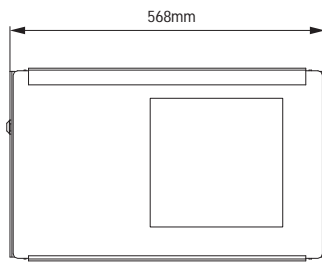

Philips Lighting Luminaires (Shanghai) Co., Ltd.
Address: No. 2688, Huyi Road, Jiading, Shanghai, China
Postalcode: 201801

飞利浦灯具(上海)有限公司
地址: 中国上海市嘉定区马陆镇沪宜公路
邮编: 201801

PHILIPS

