

# PHILIPS ADVANCE

## High Pressure Sodium Lamp Ballast

Catalog Number 71A8088  
For 100W S54  
60 Hz CWA  
Status: Active

### DIMENSIONS AND DATA

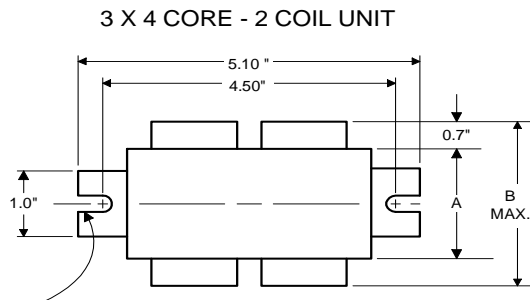

0.25" WIDE  
2 SLOTS

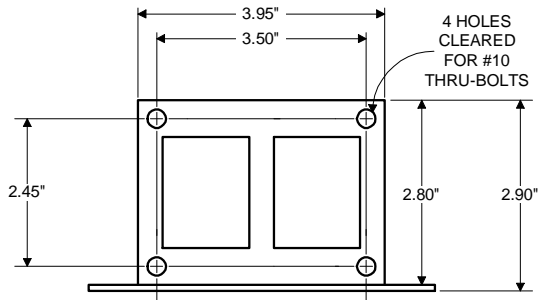

INPUT VOLTS	120	277			
CIRCUIT TYPE	CWA				
POWER FACTOR (min)	90%				
REGULATION	±10%				
Line Volts	WITHIN TRAPEZOID				
Lamp Watts					
LINE CURRENT (Amps)					
Operating.....	1.15	0.50			
Open Circuit.....	0.65	0.25			
Starting.....	0.80	0.35			
UL TEMPERATURE RATINGS	H(180°C)				
Insulation Class	1029				
Coil Temperature Code	F	F			
MIN. AMBIENT STARTING TEMP.	-40°F or -40°C				
NOM. OPEN CIRCUIT VOLTAGE	115				
INPUT VOLTAGE AT LAMP DROPOUT.....	90	208			
INPUT WATTS	138				
RECOMMENDED FUSE (Amps).....	3	2			
CORE and COIL					
Dimension (A)	2.00				
Dimension (B)	3.30				
Weight (lbs.)	7.5				
Lead Lengths	12"				
CAPACITOR REQUIREMENT					
Microfarads	34.0				
Volts (min.)	170				
Fault Current Withstand (amps)					
60 Hz TEST PROCEDURES (Refer to Advance Test Procedure for HID Ballasts - Form 1270)					
High Potential Test (Volts)					
1 minute	2000				
2 seconds	2500				
Open Circuit Voltage Test (Volts)	105-125				
Short-Circuit Current Test (Amps)					
Secondary Current	2.85-3.10				
Input Current.....	0.50-0.80	0.20-0.35	-	-	-

Capacitor: 7C340P24RA



Capacitance: 34  
Dia/Oval Dim: 1.65  
Height: 3.7  
Temp Rating: 105°C

#### Wiring Diagram:

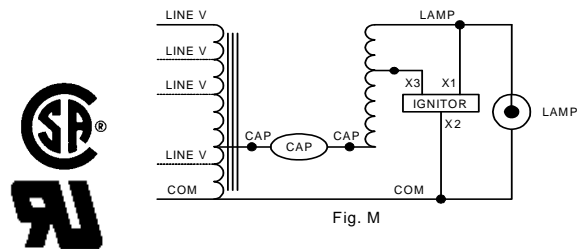

Fig. M

#### Ordering Information

Order Suffix

Description

Ignitor: LI551-J4



Red (X1)  
White (X2)  
Blue (X3)

Ballast to Lamp Distance  
(BTL) = 5 feet  
Temp Rating: 105°C

Data is based upon tests performed by Philips Lighting Electronic N.A. in a controlled environment and representative of relative performance. Actual performance can vary depending on operating conditions. Specifications are subject to change without notice.

Philips Lighting Electronic N.A.

10275 West Higgins Road · Rosemont, IL 60018 · Tel:800-322-2086 Fax:888-432-1882  
Customer Support/ Technical Service:800-372-3331 · OEM Support: 866-915-5886

06/24/13