

**PHILIPS  
ADVANCE**

**Metal  
Halide  
Lamp Ballast**

**Catalog Number 72C54C2NP900  
For 150W M102/M142  
60 Hz HX-HPF  
Status: Active**

**DIMENSIONS AND DATA**

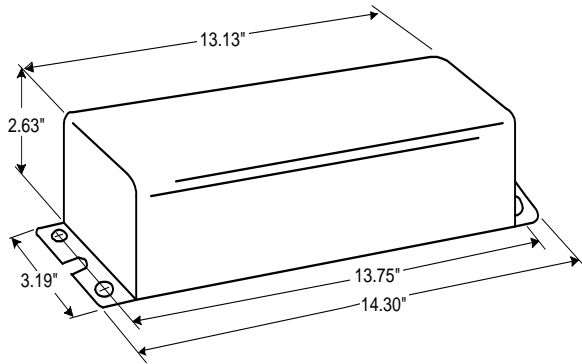

INPUT VOLTS	120	347			
CIRCUIT TYPE	HX-HPF				
POWER FACTOR (min)	90%				
REGULATION					
Line Volts	±5%				
Lamp Watts	±12%				
LINE CURRENT (Amps)					
Operating.....	1.60	0.55			
Open Circuit.....	3.65	1.25			
Starting.....	1.75	0.60			
UL TEMPERATURE RATINGS					
Insulation Class	A (105°C)				
Coil Temperature Code	1029				
MIN. AMBIENT STARTING TEMP.	-20°F or -30°C				
NOM. OPEN CIRCUIT VOLTAGE	240				
INPUT VOLTAGE AT LAMP DROPOUT.....	72	208			
INPUT WATTS	180				
RECOMMENDED FUSE (Amps).....	10	4			
CORE and COIL					
Dimension (A)					
Dimension (B)					
Weight (lbs.)	13				
Lead Lengths	12"				
CAPACITOR REQUIREMENT					
Microfarads					
Volts (min.)					
Fault Current Withstand (amps)					
60 Hz TEST PROCEDURES (Refer to Advance Test Procedure for HID Ballasts - Form 1270)					
High Potential Test (Volts)					
1 minute	1700				
2 seconds	2100				
Open Circuit Voltage Test (Volts)	215-265				
Short-Circuit Current Test (Amps)					
Secondary Current	2.15-2.65				
Input Current.....	1.00-1.50	0.35-0.55	-	-	-

Capacitor:

The capacitor is included as part of the potted assembly.

**Wiring Diagram:**

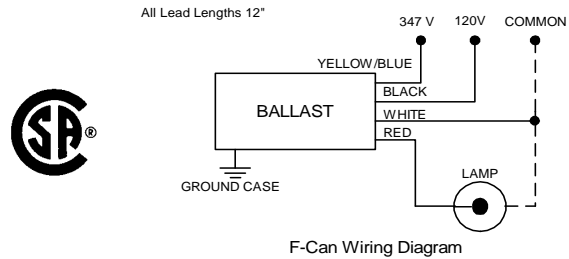

**Ordering Information**

Order Suffix	Description
IN CAN	

Ignitor: IN CAN

The ignitor is included as part of the potted assembly.

Ballast to Lamp Distance (BTL) = 50 feet  
Temp Rating: 90°C

Data is based upon tests performed by Philips Lighting Electronic N.A. in a controlled environment and representative of relative performance. Actual performance can vary depending on operating conditions. Specifications are subject to change without notice.

**Philips Lighting Electronic N.A.**

10275 West Higgins Road · Rosemont, IL 60018 · Tel:800-322-2086 Fax:888-432-1882  
Customer Support/ Technical Service:800-372-3331 · OEM Support: 866-915-5886

02/17/04