

PHILIPS
Stonco

Floodlights

General
purpose flood



Versatile & stylish for a wide range of applications



The **Philips Stonco LED General purpose floodlights** offer energy saving LED technology for long life and reduced maintenance.

With five complementary sizes to choose from, these floodlights provide uniform illumination, simplified installation, and a rugged robust design. Mounting is made easy with flexibility for ground mount, wall mount, or pole mount installations. They are an Ideal choice for sign lighting, building facades, security lighting, and general purpose floodlighting applications.

Energy savings don't get better than this – up to 79% savings compared to HID*.

* Based on comparison between 150W PSMH luminaires (at 190W) and FL40-NW-G1-K-FL-8-BZ (at 39W).



General purpose flood LED

FL20/40/80/150/300



- Complete family of LED floodlights ideal for illuminating signs, building facades or other dark areas.
- Can be mounted on the ground, wall, or pole-mounted.
- Discreet and modern design
- All sizes arrive fully assembled and ready to install. Three larger sizes have a trunnion mount and the two smaller sizes have a knuckle mount.
- Fade-resistant, textured bronze finish with tempered glass lens that is heat and impact resistant.
- IP66 rated.
- 5 year limited warranty.

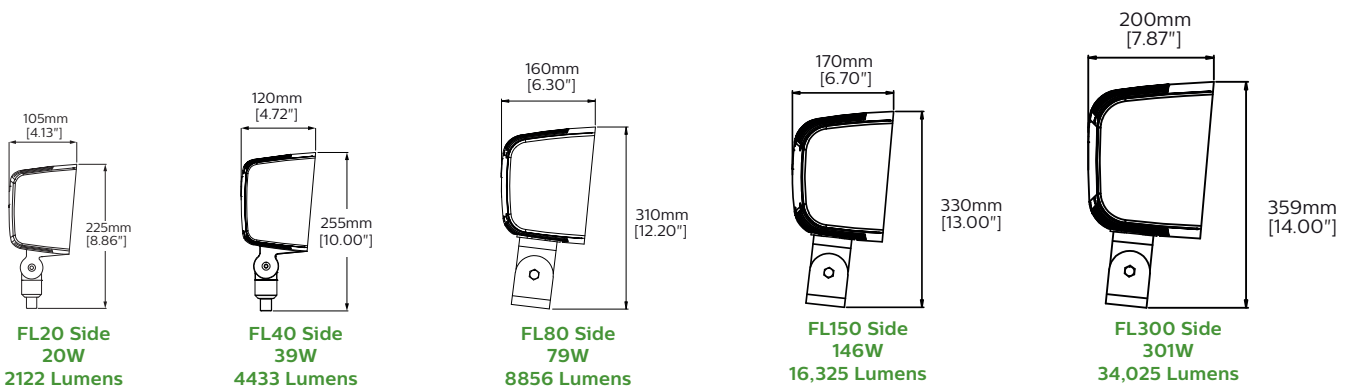

Ordering guide

example: FL150-NW-G1-T-FL-8-BZ

Luminaire	LED Color	Generation	Mounting	Distribution	Voltage	Finish
<input type="text"/>	NW	G1	<input type="text"/>	FL	8	BZ
FL20 LED Floodlight 20W FL40 LED Floodlight 40W FL80 LED Floodlight 80W FL150 LED Floodlight 150W FL300 LED Floodlight 300W	NW Neutral White 4000K, 80CRI	G1 Generation 1	K¹ Knuckle Mount ½" NPS male T² Trunnion Mount	FL Flood	8 120-277VAC	BZ Bronze

1. K Knuckle Mount only available with FL20 and FL40.
2. T Trunnion Mount only available with FL80, FL150 and FL300.

© 2017 Philips Lighting Holding B.V. All rights reserved. Philips reserves the right to make changes in specifications and/or to discontinue any product at any time without notice or obligation and will not be liable for any consequences resulting from the use of this publication. philips.com/luminaires



Philips Lighting North America Corporation
 200 Franklin Square Drive, Somerset, NJ 08873
 Tel. 855-486-2216

Philips Lighting Canada Ltd.
 281 Hillmount Rd, Markham, ON, Canada L6C 2S3
 Tel. 800-668-9008