



EFix TPS262

TPS262 2x80W/840 HFS D6 SMT WH

EFix suspended mounted, 2, 80 W, 840 neutral white, HF Standard, Semi-high-gloss optic double parabolic, White

The EFix TL5 luminaire range is a dedicated, affordable choice of innovative lighting that enables massive energy savings to be made when old electromagnetic installations are replaced by the latest Philips technology. The range's optical performance complies with the latest EN-12464 norms, ensuring improved lighting quality in every application. Used in combination with high-frequency gear, Philips MASTER TL5 lamps enable substantial energy savings to be made. These savings can be further increased by using a Luxsense daylight controller integrated into the luminaire. The practical design of EFix combines both surface-mounted (TCS260) and suspended (TPS262) luminaires in one design. Thanks to the luminaire's easily removable top cover, the beam can be adjusted to provide direct or direct/indirect lighting. EFix is supplied with lamps and is ready to install, minimizing installation time. EFix recessed TBS260 completes Philips' range of luminaires for general lighting applications in offices and shops.

Product data

General Information	
Lamp family code	TL5 [TL5]
Gear	HFS [HF Standard]
Service tag	Yes
Product family code	TPS262 [EFix suspended mounted]
Embedded control	-
CE mark	Yes
Flammability mark	For mounting on normally flammable surfaces
ENEC mark	ENEC mark

Glow-wire test	Temperature 850 °C, duration 5 s
----------------	----------------------------------

Light Technical

Number of light sources	2
Light source color	840 neutral white
Optic type	Semi-high-gloss optic double parabolic
Optical cover type	-

Operating and Electrical

Input Voltage	220 to 240 V
---------------	--------------

EFix TPS262

Power Consumption	80 W
Cable	-

Mechanical and Housing

Housing Color	White
Overall length	1,541 mm

Approval and Application

Ingress protection code	IP20 [Finger-protected]
Protection class IEC	Safety class I

Application Conditions

Suitable for random switching	Not applicable
-------------------------------	----------------

Product Data

Order product name	TPS262 2x80W/840 HFS D6 SMT WH
Full product name	TPS262 2x80W/840 HFS D6 SMT WH
Full product code	872790061425100
Order code	910402469312
Material Nr. (12NC)	910402469312
Numerator - Quantity Per Pack	1
EAN/UPC - Product/Case	8727900614251
Numerator - Packs per outer box	1
EAN/UPC - Case	8727900614251

Dimensional drawing

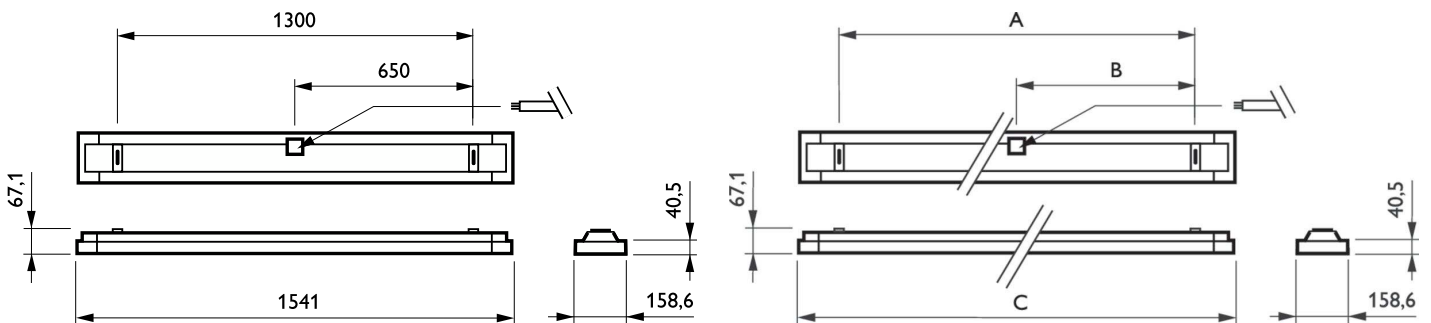

Product	B	C
TPS262 2x80W/840 HFS D6 SMT WH	650 mm	1,541 mm

