



MASTERColour CDM-Rm Elite Mini

CDM-Rm Elite Mini 35W/942 GX10 MR16 25D

Mini, very high-efficiency Ceramic Metal Halide discharge reflector lamp producing crisp white sparkling light with high colour rendering

Warnings and Safety

- Use only with electronic control gear
- Control gear must include end-of-life protection (IEC61167, IEC 62035)

Product data

General Information	
Cap-Base	GX10 [GX10]
Operating Position	UNIVERSAL [Any or Universal (U)]
Switching Cycle	1,350
Life to 50% Failures (Nom)	15,000 hour(s)

Light Technical	
Color Code	942 [CCT of 4200K]
Beam Angle (Nom)	25 degree(s)
Luminous Intensity (Nom)	7,200 cd
Chromaticity Coordinate X (Nom)	0.377
Chromaticity Coordinate Y (Nom)	0.377
Correlated Color Temperature (Nom)	4200 K
Luminous Efficacy (rated) (Nom)	57 lm/W
Color rendering index (CRI)	90
LLMF At End Of Nominal Lifetime (Nom)	73 %
Luminous Flux in 90° Cone (Rated)	2,000 lm

Operating and Electrical	
Power Consumption	39.1 W
Warm-up time to 60% light	120 s
Voltage (Nom)	90 V
Voltage (Nom)	90 V

Controls and Dimming	
Dimmable	No

Mechanical and Housing	
Bulb Shape	MR16 [2inch/50mm]

Approval and Application	
Energy Efficiency Class	G
Mercury (Hg) Content (Nom)	4.9 mg
Energy Consumption kWh/1000 h	43 kWh

Product Data	
Order product name	CDM-Rm Elite Mini 35W/942 GX10 MR16 25D

MASTERCLOUR CDM-Rm Elite Mini

Full product name	CDM-Rm Elite Mini 35W/942 GX10 MR16 25D
Full product code	871829169179200
Order code	928193005330
Material Nr. (12NC)	928193005330
Numerator - Quantity Per Pack	1

EAN/UPC - Product/Case	8718291691792
Numerator - Packs per outer box	12
EAN/UPC - Case	8718291691808

Dimensional drawing

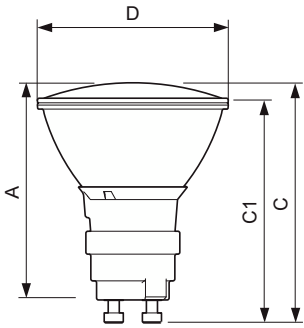

Product	D (max)	D	C (max)	C	C1 (max)	A (max)
CDM-Rm Elite Mini 35W/942 GX10 MR16 25D	51 mm	50 mm	65.4 mm	62.75 mm	60.9 mm	59 mm

Photometric data

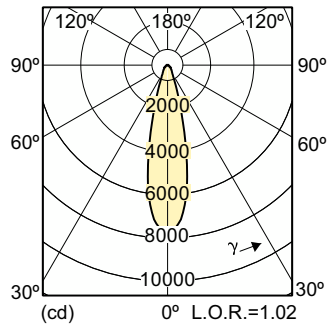

Light Distribution Diagram - CDM-Rm Elite Mini 35W/942 GX10 MR16 25D

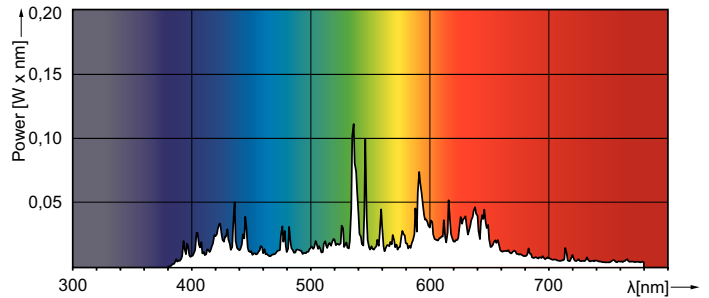

Spectral Power Distribution Colour - CDM-Rm Elite Mini 35W/942 GX10 MR16 25D

Lifetime

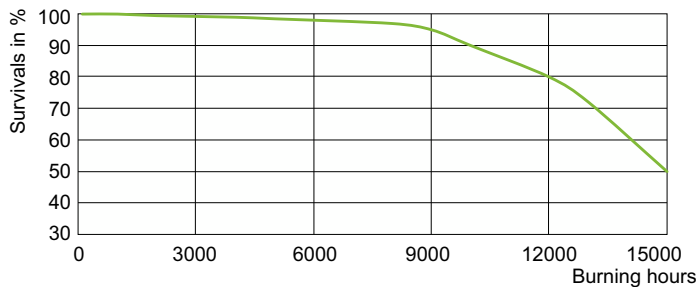

Life Expectancy Diagram - CDM-Rm Elite Mini 35W/942 GX10 MR16 25D

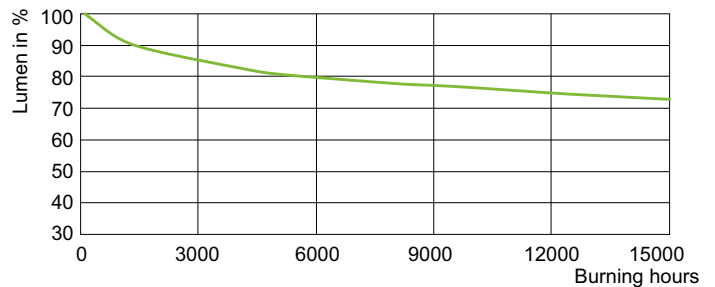

Lumen Maintenance Diagram - CDM-Rm Elite Mini 35W/942 GX10 MR16 25D

MASTERCcolour CDM-Rm Elite Mini

