



MASTERColour CDM-Rm Elite Mini

CDM-Rm Elite Mini 35W/930 GX10 MR16 25D

Mini, very high-efficiency Ceramic Metal Halide discharge reflector lamp producing crisp white sparkling light with high colour rendering

Warnings and Safety

- Use only with electronic control gear
- Use only with electronic control gear
- Control gear must include end-of-life protection (IEC61167, IEC 62035).
- Control gear must include end-of-life protection (IEC61167, IEC 62035)
- A lamp breaking is extremely unlikely to have any impact on your health. If a lamp breaks, ventilate the room for 30 minutes and remove the parts, preferably with gloves. Put them in a sealed plastic bag and take it to your local waste facilities for recycling. Do not use a vacuum cleaner.

Product data

General Information	
Cap-Base	GX10 [GX10]
Operating Position	UNIVERSAL [Any or Universal (U)]
Switching Cycle	1,350
Flux measurement reference	Narrow Cone
Life to 50% Failures (Nom)	15,000 hour(s)

Light Technical	
Color Code	930 [CCT of 3000K]
Beam Angle (Nom)	25 degree(s)
Luminous Flux	2,150 lm
Luminous Intensity (Nom)	7,600 cd
Chromaticity Coordinate X (Nom)	0.434
Chromaticity Coordinate Y (Nom)	0.398

Correlated Color Temperature (Nom)	3000 K
Luminous Efficacy (rated) (Nom)	60 lm/W
Color rendering index (CRI)	90
LLMF At End Of Nominal Lifetime (Nom)	80 %
Luminous Flux in 90° Cone (Rated)	2,150 lm

Operating and Electrical	
Power Consumption	39.1 W
Warm-up time to 60% light	120 s
Voltage (Nom)	87 V
Voltage (Nom)	87 V

MASTERC colour CDM-Rm Elite Mini

Controls and Dimming

Dimmable	No
----------	----

Mechanical and Housing

Bulb Shape	MR16 [2inch/50mm]
------------	-------------------

Approval and Application

Energy Efficiency Class	G
Mercury (Hg) Content (Max)	4.7 mg
Mercury (Hg) Content (Nom)	4.7 mg
Energy Consumption kWh/1000 h	40 kWh
EPREL Registration Number	473277

Product Data

Order product name	CDM-Rm Elite Mini 35W/930 GX10 MR16 25D
Full product name	CDM-Rm Elite Mini 35W/930 GX10 MR16 25D
Full product code	871829116300800
Order code	928194705330
Material Nr. (12NC)	928194705330
Numerator - Quantity Per Pack	1
EAN/UPC - Product/Case	8718291163008
Numerator - Packs per outer box	12
EAN/UPC - Case	8718291163015

Dimensional drawing

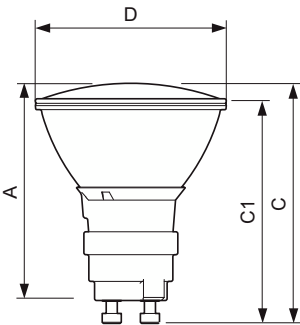

Product	D (max)	D	C (max)	C	C1 (max)	A (max)
CDM-Rm Elite Mini 35W/930 GX10 MR16 25D	51 mm	50 mm	65.4 mm	62.75 mm	60.9 mm	59 mm

Photometric data

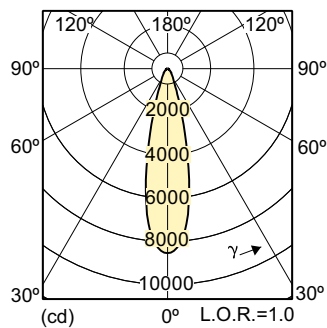

Light Distribution Diagram - CDM-Rm Elite Mini 35W/930 GX10 MR16 25D

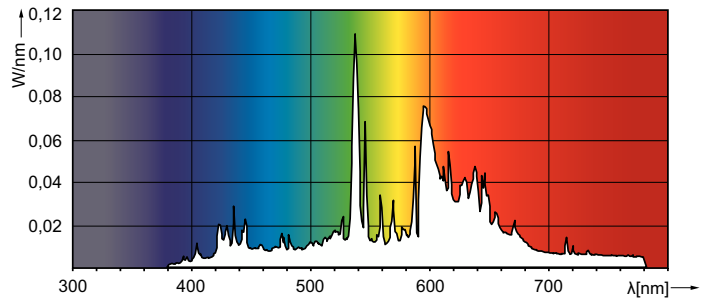

Spectral Power Distribution Colour - CDM-Rm Elite Mini 35W/930 GX10 MR16 25D

MASTERCcolour CDM-Rm Elite Mini

Lifetime

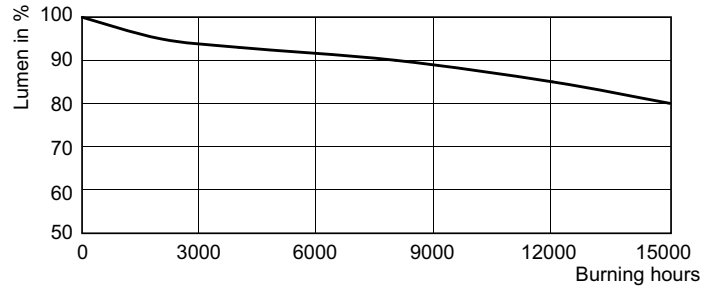
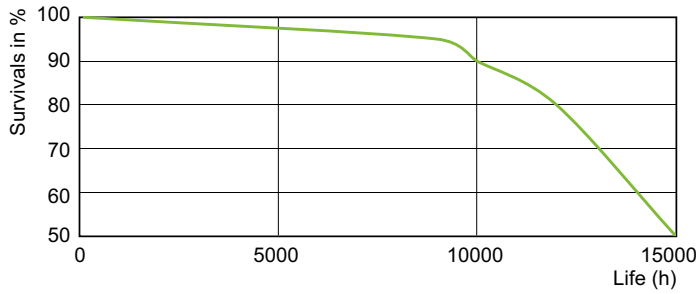

Life Expectancy Diagram - CDM-Rm Elite Mini 35W/930 GX10 MR16 25D

Lumen Maintenance Diagram - CDM-Rm Elite Mini 35W/930 GX10 MR16 25D

