



LED PAR38

120V PAR38 17W 35D 2700K 1200 D AF SO

Philips LED spots with a single optic beam, provide a clean beam that's free from shadows with beam angles from 15 and 40 degrees to suit every general lighting application.

Product data

| General Information | |
|---------------------|-----------------------------------|
| Cap-Base | E26 [Single Contact Medium Screw] |
| Nominal lifetime | 25,000 hour(s) |
| Switching Cycle | 50,000 |
| Lighting Technology | LED |
| EU RoHS compliant | Yes |

| Light Technical | |
|---------------------------------------|--------------------|
| Color Code | 827 [CCT of 2700K] |
| Beam Angle (Nom) | 35 degree(s) |
| Luminous Flux | 1,200 lm |
| Luminous Intensity (Nom) | 3,200 cd |
| Color Designation | Warm White (WW) |
| Correlated Color Temperature (Nom) | 2700 K |
| Luminous Efficacy (rated) (Nom) | 71 lm/W |
| Color Consistency | <6 |
| Color rendering index (CRI) | 80 |
| LLMF At End Of Nominal Lifetime (Nom) | 70 % |

| Operating and Electrical | |
|--------------------------|--------|
| Line Frequency | 60 Hz |
| Input Frequency | 60 Hz |
| Power Consumption | 17 W |
| Lamp Current (Nom) | 167 mA |

| | |
|---------------------------|-------|
| Wattage Equivalent | 120 W |
| Starting Time (Nom) | 0.5 s |
| Warm-up time to 60% light | 0.5 s |
| Power Factor (Fraction) | 0.85 |
| Voltage (Nom) | 120 V |

| Temperature | |
|----------------------|-------|
| T-Case Maximum (Nom) | 89 °C |

| Controls and Dimming | |
|----------------------|-----|
| Dimmable | Yes |

| Mechanical and Housing | |
|------------------------|-----------------------------|
| Bulb Shape | PAR38 [PAR 4.75 inch/121mm] |

| Approval and Application | |
|------------------------------|-----|
| Suitable For Accent Lighting | Yes |

| Product Data | |
|-------------------------------|---------------------------------------|
| Order product name | 120V PAR38 17W 35D 2700K 1200 D AF SO |
| Full product name | 120V PAR38 17W 35D 2700K 1200 D AF SO |
| Order code | 929001113704 |
| Material Nr. (12NC) | 929001113704 |
| Numerator - Quantity Per Pack | 1 |

LED PAR38

| | |
|---------------------------------|----------------|
| EAN/UPC - Product/Case | 046677435417 |
| Numerator - Packs per outer box | 6 |
| EAN/UPC - Case | 50046677435412 |

Dimensional drawing

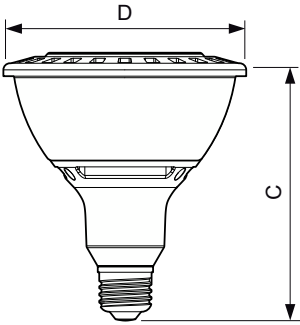

| Product | D | C |
|---------------------------------------|----------|----------|
| 120V PAR38 17W 35D 2700K 1200 D AF SO | 120.3 mm | 130.5 mm |

Photometric data

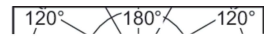
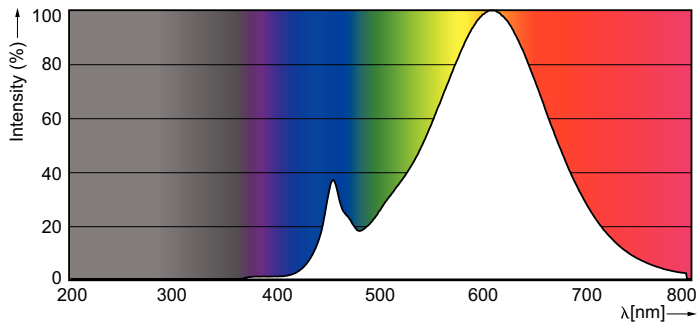

Spectral Power Distribution Colour - 120V PAR38 17W 35D 2700K 1200 D AF SO

Light Distribution Diagram - 120V PAR38 17W 35D 2700K 1200 D AF SO

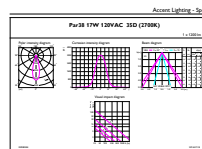

General uniform lighting - 120V PAR38 17W 35D 2700K 1200 D AF SO

LED PAR38

