

# PHILIPS ADVANCE

Metal  
Halide  
Lamp Ballast

Catalog Number 71A6593  
For 1000W M141 (Pulse Start)  
60 Hz SUPER-CWA  
Status: Active

## DIMENSIONS AND DATA

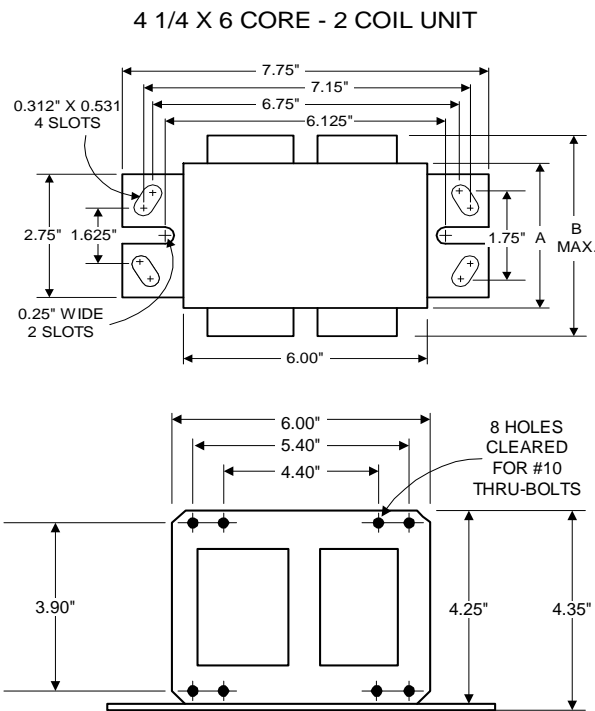

	120	208	240	277
INPUT VOLTS				
CIRCUIT TYPE	SUPER-CWA			
POWER FACTOR (min)	90%			
REGULATION				
Line Volts	±10%			
Lamp Watts	±12%			
LINE CURRENT (Amps)				
Operating.....	9.00	5.20	4.50	3.90
Open Circuit.....	4.50	2.70	2.30	2.20
Starting.....	7.80	4.00	3.70	3.20
UL TEMPERATURE RATINGS				
Insulation Class	H(180°C)			
Coil Temperature Code	1029			
MIN. AMBIENT STARTING TEMP.	-20°F or -30°C			
NOM. OPEN CIRCUIT VOLTAGE	430			
INPUT VOLTAGE AT LAMP DROPOUT.....	84	146	168	194
INPUT WATTS	1080			
RECOMMENDED FUSE (Amps).....	20	15	10	10
CORE and COIL				
Dimension (A)	2.80			
Dimension (B)	4.50			
Weight (lbs.)	21			
Lead Lengths	12"			
CAPACITOR REQUIREMENT				
Microfarads	24.0			
Volts (min.)	480			
Fault Current Withstand (amps)				
60 Hz TEST PROCEDURES (Refer to Advance Test Procedure for HID Ballasts - Form 1270)				
High Potential Test (Volts)				
1 minute	1500			
2 seconds	2500			
Open Circuit Voltage Test (Volts)	385-475			
Short-Circuit Current Test (Amps)				
Secondary Current	5.20-6.40			
Input Current.....	5.60-8.60	3.20-4.80	2.80-4.30	2.40-3.75

Capacitor: MD2409-000

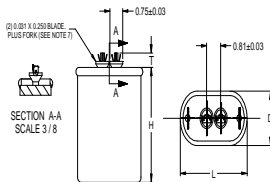

Capacitance: 24  
Dia/Oval Dim: 1.75  
Height: 3.9  
Temp Rating: 90°C

### Wiring Diagram:

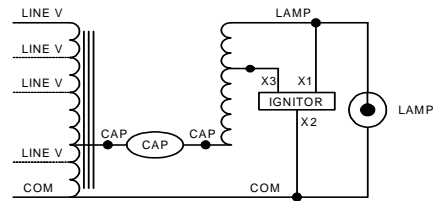
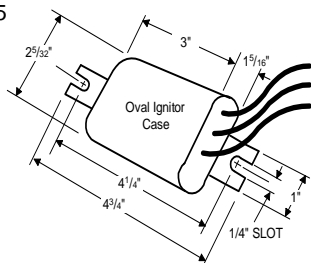

Fig. M

Ignitor: LI571-H5



Ballast to Lamp Distance (BTL) = 5 feet  
Temp Rating: 105°C

### Ordering Information

Order Suffix	Description
500.	Ballast with Ignitor and Oil Filled Capacitor
510.	Ballast w/Welded Bracket, Ignitor & Oil-Filled Capacitor

Data is based upon tests performed by Philips Lighting Electronic N.A. in a controlled environment and representative of relative performance. Actual performance can vary depending on operating conditions. Specifications are subject to change without notice.

Philips Lighting Electronic N.A.

10275 West Higgins Road · Rosemont, IL 60018 · Tel:800-322-2086 Fax:888-432-1882  
Customer Support/ Technical Service:800-372-3331 · OEM Support: 866-915-5886

10/09/00