

CAUTION
HIGH VOLTAGE
CABLES UNDER
SEABS IN
TOWING PATH



iW Graze Powercore Family

Linear exterior LED wall grazing luminaires with intelligent white light

iW Graze MX Powercore

iW Graze QLX Powercore

iW Graze QLX Powercore 5W

iW Graze EC Powercore

PHILIPS



iW Graze Powercore Family

Linear exterior LED wall grazing luminaires with intelligent white light

The new iW Graze Powercore family dramatically extends the range and flexibility of the popular line of intelligent white light LED grazing luminaires from Philips Color Kinetics. These high-performance luminaires offer channels of cool, neutral, and warm white LEDs to offer color temperatures ranging from 2700 K to 6500 K. Multiple luminaire lengths, beam angles, output levels, and power consumption levels support a large range of façade or surface illumination application. Low-profile housing, connectorized cabling, a universal power input range, and direct line-voltage operation make iW Graze Powercore luminaires easy to install and operate.

- Tailor light output to specific applications—Available in four standard lengths, with standard 9° x 9°, 10° x 60°, 15° x 30°, 30° x 60° and 60° x 30° beam angles. Individually addressable 305 mm (1 ft) segments accommodate fine control of white-only effects and pre-programmed light shows.
- High-performance illumination and beam quality—iW Graze Powercore delivers up to 860 lumens of color temperature-adjustable light per foot. Superior beam quality offers striation-free saturation for several feet from luminaire placement with no visible light scalloping between luminaires.
- Integrates Powercore technology—Powercore technology rapidly, efficiently, and accurately controls power output to luminaires directly from line voltage. The Philips Data Enabler Pro merges line voltage with control and delivers them to the luminaire over a single standard cable, dramatically simplifying installation and lowering total system cost.
- Versatile installation options—Convenient push-and-click connectors let you easily and rapidly install Leader Cables and Jumper Cables. Multiple cable lengths support a variety of layouts. Constant torque locking hinges offer simple and consistent position control from various angles. The low-profile aluminium housing accommodates placement within most architectural niches.
- Superior color consistency and accuracy—Optibin, an advanced binning algorithm, sets a new standard for the color consistency and uniformity of LED sources used in manufacturing. Chromasync technology achieves unprecedented consistency of light performance and color precision across multiple luminaires in an installation, while maximizing intensity and color range.
- Universal power input range—Luminaires accept a universal power input range of 100 to 277 VAC for consistent installation anywhere in the world.



High performance + easy installation

With flexible mounting options, multiple luminaire length and beam angle options, integrated Powercore technology, and a discreet low-profile housing rated for use in outdoor locations, iW Graze Powercore offers high performance and simple installation.

Illuminate surfaces with the right level of light

The expanded range of iW Graze Powercore intelligent white light grazing fixtures offer four levels of performance at four levels of power consumption. A range of beam angles lets you select exactly the right light distribution and output for your application.

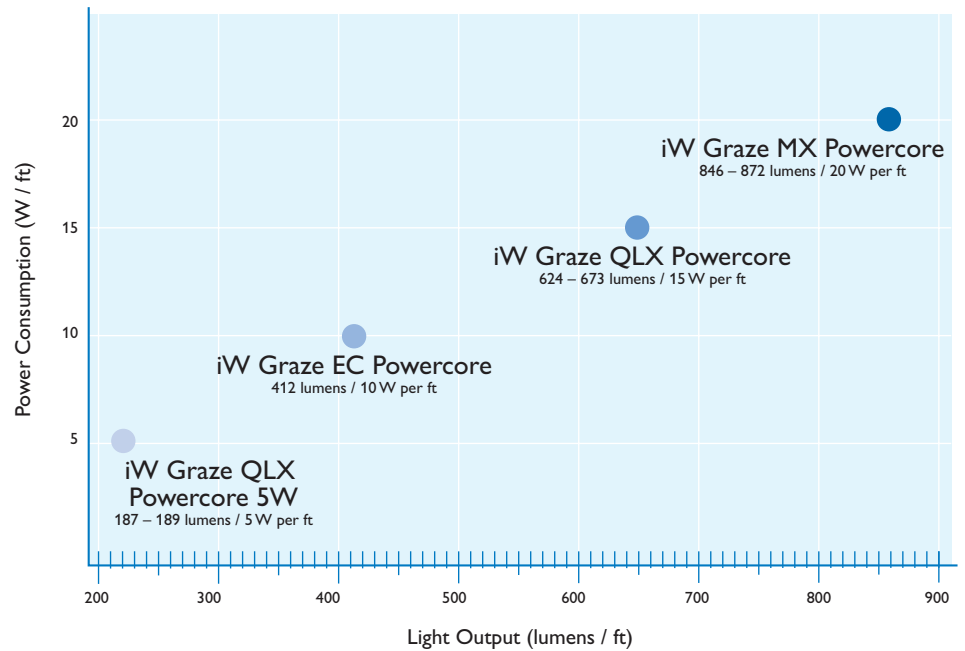

iW Graze MX Powercore

Features the most light output in our line of intelligent white light grazing luminaires — more than any previous version — for high-intensity multi-story façade and surface illumination.

iW Graze QLX Powercore

Consumes 25% less energy than iW Graze MX Powercore. Perfect for surface illumination applications calling for a balance of cost and performance.

iW Graze QLX Powercore 5W

Luminaires are factory-set to consume a maximum of 5 W per foot, to support ASHRAE standards, LEED green building certification, and other power-limited projects. Offers the same beam spread options as iW Graze MX Powercore and iW Graze QLX Powercore.

iW Graze EC Powercore

Wide beam angle (90° x 90°) produces a soft-edged, volume fill for exterior cove, niche, and architectural detail illumination.

How Different Color Temperatures Affect the Appearance of Objects



Warm Color Temperature



Cool Color Temperature

Adjusting the brightness and color temperature of iW Graze Powercore luminaires, from warm (more yellow and red) through neutral to cool (more blue), alters the emotional effect of a space, and can dramatically affect the appearance of objects on displays in stores, galleries, and museums. Selecting the right color temperature matches light source to environment, positively influences buyer behavior, and increases productivity in the workplace.

Effect, Mood, and Application by Color Temperature					
Color Temperature	Warm 2700 K	White 3000 K	Neutral 3500 K	Cool 4100 K	Daylight 5000 K – 6500 K
Effects and Moods	Warm Cozy Open	Friendly Intimate Personal Exclusive	Friendly Inviting Non-threatening	Neat Clean Efficient	Bright Alert Exacting coloration
Applications	Restaurants Hotel lobbies Boutiques Homes	Libraries Office areas Retail stores	Showrooms Bookstores Office areas	Office areas Classrooms Mass merchandisers Hospitals	Galleries Museums Jewelry stores Medical exam areas

Delivering a Wide Range of Color Temperatures

LED sources can deliver a wide range of color temperatures, equivalent to the color temperatures available from conventional fluorescent, incandescent, halogen, and metal halide light sources. IntelliWhite luminaires from Philips Color Kinetics offer this range in a single luminaire.

Light Sources and Their Color Temperatures					
Color Temperature	Fluorescent	Halogen	Incandescent	LED	Metal Halide
Warm 2700 K	✓		✓	✓	
White 3000 K	✓	✓		✓	✓
Normal 3500 K	✓			✓	
Cool 4100 K	✓			✓	✓
Daylight 5000 K to 6500 K	✓			✓	

Versatile Installation Options

iW Graze Powercore is designed for grazing and wall washing applications which require variable brightness and color temperature. With a low-profile design, exterior-rated housing, LED sources with long useful life, and ease of installation and maintenance, iW Graze Powercore is ideal for interior and exterior installations where lamp maintenance may be difficult or impossible.

Typical iW Graze Powercore Installations

Thanks to patented Powercore technology, Data Enabler Pro delivers line voltage and control data to iW Graze Powercore luminaires over a single standard wire, eliminating the need for external power supplies,

A simple iW Graze Powercore installation might use a single series of luminaires with one Data Enabler Pro and ColorDial Pro to wash the walls in an office entryway with uniform, surface wash light that reflects a glare-free ambient glow into the surrounding area. A more complex installation might use multiple series of iW Graze Powercore luminaires, with multiple Data Enabler Pro devices, mounted in within compact niches of a building exterior for dramatic highlighting of notable architectural features.

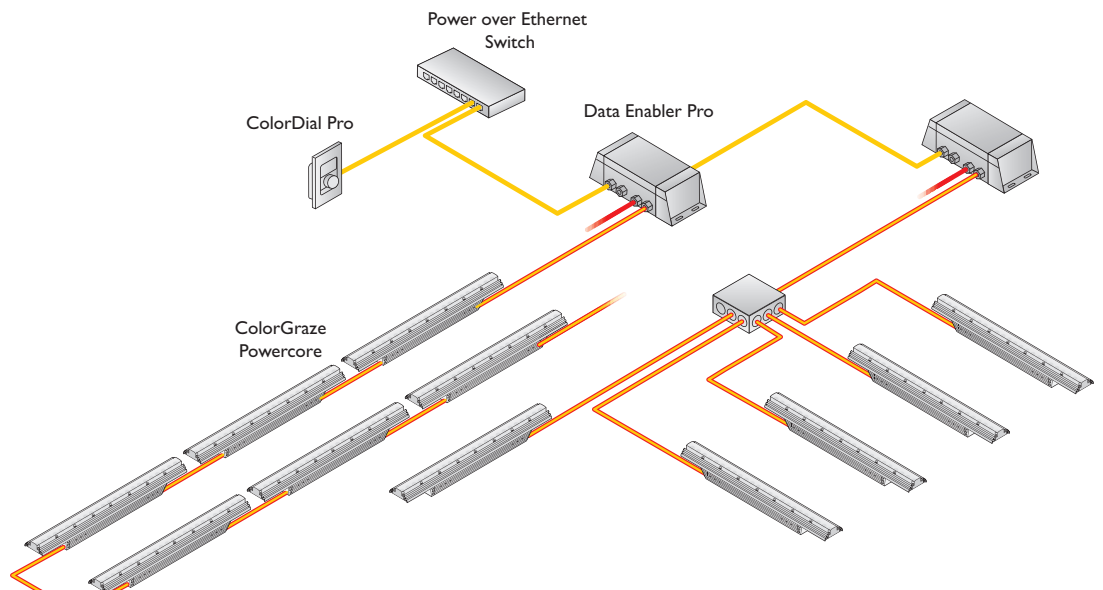

Regardless of the size and complexity of your installation, planning up front can help streamline the installation and configuration of your luminaires.

Create a lighting design plan that identifies and locates all luminaires, power/data supplies, and controllers. Use this Product Guide and the online Configuration Calculator to determine whether to install luminaires in series or in parallel, how many luminaires you can install in a single series, and the maximum distances between Data Enabler Pro devices, luminaires, and controllers.

Photometrics/iW Graze MX Powercore

Photometric data is based on test results from an independent NIST traceable testing lab. IES data is available at www.philipscolorkinetics.com/support/ies.

305 mm (1 ft), 9° x 9° beam angle

Lumens	Efficacy
872	34.9

Polar Candela Distribution

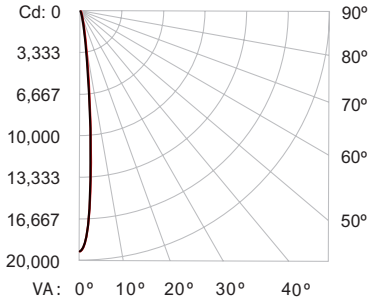

	0.0	22.5	45.0	67.5	90.0
0	19025	19025	19025	19025	19025
5	8691	8898	9361	9826	10013
15	665	615	582	615	642
25	83	68	68	64	65
35	23	20	21	22	22
45	8	8	10	9	11
55	6	5	4	5	6
65	4	4	3	3	3
75	1	1	0	0	1
85	1	0	0	0	1
90	0	0	0	0	0

Illuminance at Distance

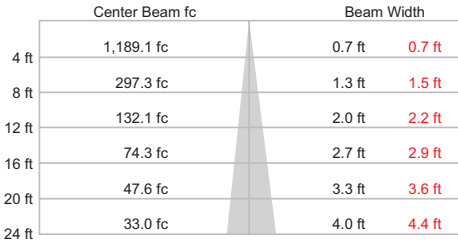

138 ft (42 m) 1 fc maximum distance
Vert. Spread: 9.5°
Horiz. Spread: 10.4°

Coefficients Of Utilization - Zonal Cavity Method

Effective Floor Cavity Reflectance: 20%

RC	80	70	50	30	10	0
RW	70 50 30 10	70 50 30 10	50 30 10	50 30 10	50 30 10	0
0	119119119119	116116116116	1111111111	106106106	102102102	100
1	116114113111	114112111109	108107106	104104103	101101100	98
2	113110108106	111109106105	105104102	103101100	100 99 98	97
3	111107104102	109106103101	103101 99	101 99 98	99 98 97	95
4	108104101 99	107103100 98	101 99 97	100 98 96	98 96 95	94
5	106102 99 96	105101 98 96	100 97 95	98 96 95	97 95 94	93
6	105100 97 95	103 99 96 94	98 96 94	97 95 93	96 94 93	92
7	103 98 95 93	102 98 95 93	97 94 92	96 94 92	95 93 92	91
8	101 97 94 92	101 96 93 91	95 93 91	95 92 91	94 92 91	90
9	100 95 92 90	99 95 92 90	94 92 90	94 91 90	93 91 90	89
10	99 94 91 89	98 94 91 89	93 91 89	93 90 89	92 90 89	88

Zonal Lumen

ZONE	LUMENS	%FIXT
0- 30	842	96.6
0- 40	856	98.2
0- 60	867	99.5
0- 90	872	100.0
90-120	0	0.0
90-130	0	0.0
90-150	0	0.0
90-180	0	0.0
0-180	872	100.0

305 mm (1 ft), 10° x 60° beam angle

Lumens	Efficacy
860	34.0

Polar Candela Distribution

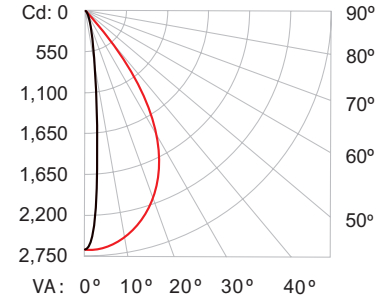

	0.0	22.5	45.0	67.5	90.0
0	3217	3217	3217	3217	3217
5	1559	1729	2271	2926	3197
15	199	242	417	1186	3001
25	32	39	101	432	2437
35	13	15	29	167	1448
45	7	8	14	52	501
55	6	6	7	18	114
65	4	4	4	8	35
75	2	2	2	4	12
85	1	1	1	1	1
90	1	1	1	0	0

Illuminance at Distance

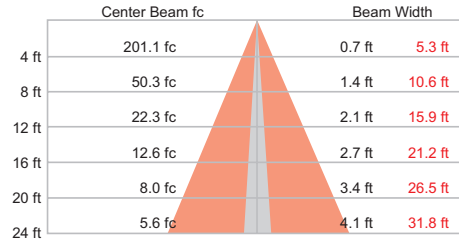

56 ft (17 m) 1 fc maximum distance
Vert. Spread: 9.8°
Horiz. Spread: 67.1°

Coefficients Of Utilization - Zonal Cavity Method

Effective Floor Cavity Reflectance: 20%

RC	80	70	50	30	10	0
RW	70 50 30 10	70 50 30 10	50 30 10	50 30 10	50 30 10	0
0	119119119119	116116116116	1111111111	106106106	102102102	100
1	114111109106	111109107105	105103102	101100 99	98 97 96	94
2	108104100 97	106102 99 96	99 96 93	96 94 91	93 91 90	88
3	103 97 93 89	101 96 92 88	93 90 87	91 88 85	89 86 84	83
4	99 92 86 82	97 90 86 82	88 84 81	86 83 80	85 82 79	78
5	94 86 81 77	93 86 80 77	84 79 76	82 78 75	81 77 75	73
6	90 82 76 72	89 81 76 72	80 75 72	78 74 71	77 73 71	69
7	86 76 72 68	85 77 72 68	76 71 68	75 71 67	74 70 67	66
8	83 74 69 65	82 74 68 65	72 68 64	71 67 64	71 67 64	63
9	80 71 65 62	79 70 65 62	69 65 61	68 64 61	68 64 61	60
10	77 68 62 59	76 67 62 59	66 62 59	66 61 58	65 61 58	57

Zonal Lumen

ZONE	LUMENS	%FIXT
0- 30	638	74.1
0- 40	767	89.1
0- 60	846	98.3
0- 90	860	100.0
90-120	0	0.0
90-130	0	0.0
90-150	0	0.0
90-180	0	0.0
0-180	860	100.0

305 mm (1 ft), 15° x 30° beam angle

Lumens	Efficacy
846	33.3

Polar Candela Distribution

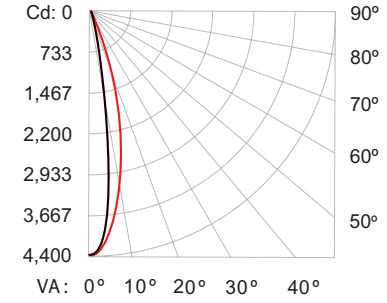

	0.0	22.5	45.0	67.5	90.0
0	4380	4380	4380	4380	4380
5	3475	3549	3750	3951	4046
15	693	785	1116	1689	2054
25	97	114	180	351	518
35	26	28	38	62	86
45	13	13	16	21	25
55	9	8	9	11	13
65	6	6	5	7	7
75	3	3	3	3	4
85	2	1	1	1	1
90	1	1	1	1	0

Illuminance at Distance

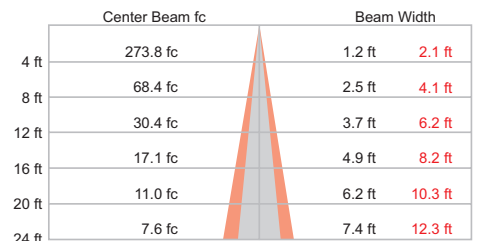

66 ft (20.1 m) 1 fc maximum distance
Vert. Spread: 17.5°
Horiz. Spread: 28.8°

Coefficients Of Utilization - Zonal Cavity Method

Effective Floor Cavity Reflectance: 20%

RC	80	70	50	30	10	0
RW	70 50 30 10	70 50 30 10	50 30 10	50 30 10	50 30 10	0
0	119119119119	116116116116	1111111111	106106106	102102102	100
1	115113111109	112110109107	106105104	103102101	99 99 98	96
2	111107104101	109105103100	102100 98	99 98 96	97 95 94	92
3	107102 99 96	105101 98 95	98 96 93	96 94 92	94 92 91	89
4	104 98 94 91	102 97 93 90	95 92 89	93 91 88	92 89 87	86
5	101 94 90 87	99 94 90 87	92 89 86	90 88 85	89 87 85	83
6	98 91 87 84	96 90 86 84	89 86 83	88 85 83	87 84 82	81
7	95 88 84 81	94 88 84 81	87 83 80	85 82 80	85 82 80	79
8	92 86 81 78	91 85 81 78	84 81 78	83 80 78	82 80 77	76
9	90 83 79 76	89 83 79 76	82 78 76	81 78 76	80 77 75	74
10	88 81 77 74	87 80 77 74	80 76 74	79 76 74	78 76 73	73

Zonal Lumen

ZONE	LUMENS	%FIXT
0- 30	781	92.3
0- 40	812	96.1
0- 60	835	98.7
0- 90	846	100.0
90-120	0	0.0
90-130	0	0.0
90-150	0	0.0
90-180	0	0.0
0-180	846	100.0

305 mm (1 ft), 30° x 60° beam angle

Lumens	Efficacy
855	33.4

Polar Candela Distribution

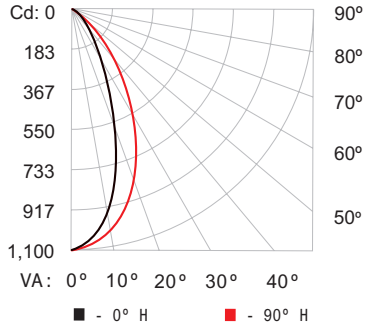

	0.0	22.5	45.0	67.5	90.0
0	1094	1094	1094	1094	1094
5	1053	1056	1064	1073	1076
15	752	775	837	905	935
25	379	411	507	630	690
35	131	152	223	342	414
45	41	47	74	141	193
55	20	20	25	47	70
65	11	11	12	17	23
75	4	4	5	6	7
85	2	2	1	1	1
90	1	1	0	0	0

Illuminance at Distance

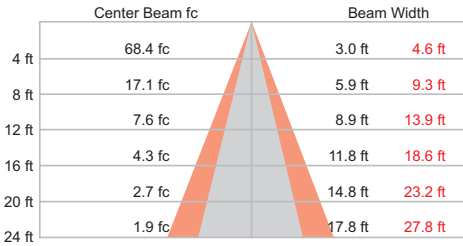

33 ft (10 m)
1 fc maximum distance

Vert. Spread: 40.6°
Horiz. Spread: 60.2°

Coefficients Of Utilization - Zonal Cavity Method

Effective Floor Cavity Reflectance: 20%

RC	80	70	50	30	10	0
RW	70 50 30 10	70 50 30 10	50 30 10	50 30 10	50 30 10	50 30 10 0
0	119119119119	116116116116	1111111111	106106106	102102102	100
1	113110107105	111108106103	104102100	100 99 97	97 95 94	93
2	107102 98 94	105100 96 93	97 94 91	94 91 89	91 89 87	85
3	101 94 89 85	99 93 88 84	90 86 83	88 84 82	86 83 80	79
4	96 88 82 78	94 87 81 77	85 80 76	82 78 75	81 77 74	73
5	91 82 76 71	89 81 75 71	79 74 70	78 73 70	76 72 69	68
6	86 77 71 66	85 76 70 66	74 69 65	73 68 65	72 68 64	63
7	82 72 66 61	80 71 65 61	70 65 61	69 64 61	68 64 60	59
8	78 68 62 57	76 67 61 57	66 61 57	65 60 57	64 60 57	55
9	74 64 58 54	73 64 58 54	63 57 54	62 57 53	61 56 53	52
10	71 61 55 51	70 60 54 51	59 54 50	59 54 50	58 53 50	49

Zonal Lumen

ZONE	LUMENS	%FIXT
0- 30	569	66.5
0- 40	726	84.8
0- 60	834	97.4
0- 90	855	100.0
90-120	0	0.0
90-130	0	0.0
90-150	0	0.0
90-180	0	0.0
0-180	855	100.0

305 mm (1 ft), 60° x 30° beam angle

Lumens	Efficacy
872	34.1

Polar Candela Distribution

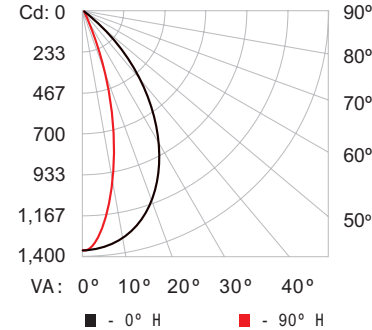

	0.0	22.5	45.0	67.5	90.0
0	1342	1342	1342	1342	1342
5	1332	1315	1282	1252	1238
15	1237	1113	872	691	629
25	1036	757	383	213	173
35	703	373	116	54	43
45	336	132	36	23	21
55	109	42	17	14	14
65	28	16	10	9	9
75	8	5	4	4	4
85	4	2	1	1	1
90	2	1	1	0	0

Illuminance at Distance

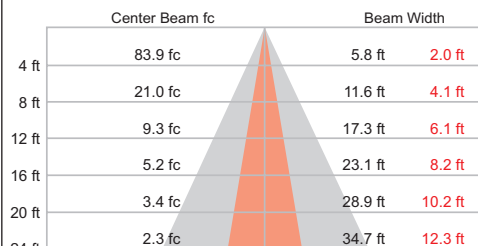

36 ft (11 m)
1 fc maximum distance

Vert. Spread: 71.7°
Horiz. Spread: 28.7°

Coefficients Of Utilization - Zonal Cavity Method

Effective Floor Cavity Reflectance: 20%

RC	80	70	50	30	10	0
RW	70 50 30 10	70 50 30 10	50 30 10	50 30 10	50 30 10	50 30 10 0
0	119119119119	116116116116	1111111111	106106106	102102102	100
1	113110108105	111108106104	104102100	100 99 97	97 96 95	93
2	107102 98 94	105100 97 93	97 94 91	94 92 89	91 89 87	86
3	102 95 90 86	100 94 89 85	91 87 84	88 85 82	86 83 81	79
4	96 89 83 79	95 87 82 78	85 81 77	83 79 76	81 78 75	74
5	92 83 77 73	90 82 76 72	80 75 72	78 74 71	77 73 70	69
6	87 78 72 67	85 77 71 67	76 70 67	74 70 66	73 69 66	64
7	83 73 67 63	81 73 67 63	71 66 62	70 66 62	69 65 62	60
8	79 69 63 59	78 69 63 59	68 62 59	67 62 58	66 61 58	57
9	75 66 60 56	74 65 59 55	64 59 55	63 58 55	62 58 55	54
10	72 62 56 53	71 62 56 52	61 56 52	60 55 52	59 55 52	51

Zonal Lumen

ZONE	LUMENS	%FIXT
0- 30	596	68.4
0- 40	744	85.4
0- 60	850	97.5
0- 90	871	99.9
90-120	1	0.1
90-130	1	0.1
90-150	1	0.1
90-180	1	0.1
0-180	872	100.0

For lux multiply fc by 10.7

Photometrics/iW Graze QLX Powercore

Photometric data is based on test results from an independent NIST traceable testing lab. IES data is available at www.philipscolorkinetics.com/support/ies.

305 mm (1 ft), 9° x 9° beam angle

Lumens	Efficacy
661	33.7

Polar Candela Distribution

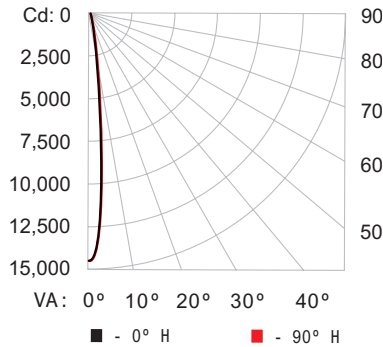

	0.0	22.5	45.0	67.5	90.0
0	14187	14187	14187	14187	14187
5	6608	6739	6901	7142	7257
15	512	478	458	481	508
25	66	57	57	56	54
35	18	15	17	20	18
45	8	6	9	9	9
55	5	3	5	3	3
65	3	2	3	3	3
75	0	0	0	0	0
85	0	0	0	0	0
90	0	0	0	0	0

Illuminance at Distance

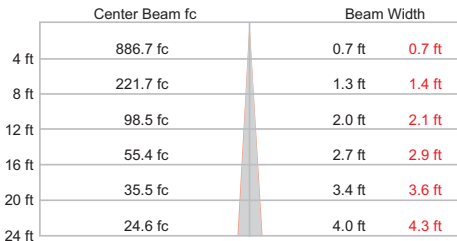

119 ft (36.3 m) 1 fc maximum distance
■ Vert. Spread: 9.6° ■ Horiz. Spread: 10.2°

Coefficients Of Utilization - Zonal Cavity Method

RC	Effective Floor Cavity Reflectance: 20%											
	80	70	50	30	10	0	80	70	50	30	10	0
RW	70	50	30	10	0	0	70	50	30	10	0	0
0	119119119119	116116116116	1111111111	106106106	102102102	100	119119119119	116116116116	1111111111	106106106	102102102	100
1	113110107104	110107105103	10310199	1009896	969594	92	113110107104	110107105103	10310199	1009896	969594	92
2	1061019692	104999591	969289	939087	908886	84	1061019692	104999591	969289	939087	908886	84
3	100938783	98928682	898481	868380	848178	77	100938783	98928682	898481	868380	848178	77
4	94868075	93857975	837874	817673	797572	70	94868075	93857975	837874	817673	797572	70
5	89807369	87797368	777268	757167	747066	65	89807369	87797368	777268	757167	747066	65
6	84746863	83746763	726762	716662	696562	60	84746863	83746763	726762	716662	696562	60
7	80706358	78696358	676258	666158	656157	56	80706358	78696358	676258	666158	656157	56
8	75655954	74655854	635854	625754	615753	52	75655954	74655854	635854	625754	615753	52
9	72615551	70615551	605450	595450	585350	48	72615551	70615551	605450	595450	585350	48
10	68585247	67575147	565147	555147	555047	45	68585247	67575147	565147	555147	555047	45

Zonal Lumen

ZONE	LUMENS	%FIXT
0-30	636	96.3
0-40	647	98.0
0-60	657	99.5
0-90	661	100.0
90-120	0	0.0
90-130	0	0.0
90-150	0	0.0
90-180	0	0.0
0-180	661	100.0

305 mm (1 ft), 10° x 60° beam angle

Lumens	Efficacy
624	31.5

Polar Candela Distribution

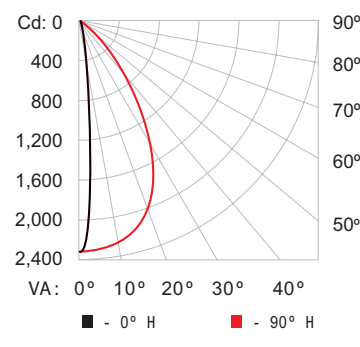

	0.0	22.5	45.0	67.5	90.0
0	2300	2300	2300	2300	2300
5	1112	1232	1608	2089	2290
15	139	171	295	852	2161
25	22	28	74	310	1776
35	9	11	22	124	1098
45	5	6	10	41	407
55	3	4	5	15	93
65	2	2	3	6	28
75	1	1	2	3	10
85	0	0	1	1	1
90	0	0	0	0	0

Illuminance at Distance

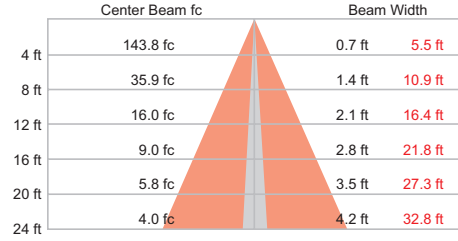

48 ft (14.6 m) 1 fc maximum distance
■ Vert. Spread: 10.0° ■ Horiz. Spread: 68.6°

Coefficients Of Utilization - Zonal Cavity Method

RC	Effective Floor Cavity Reflectance: 20%											
	80	70	50	30	10	0	80	70	50	30	10	0
RW	70	50	30	10	0	0	70	50	30	10	0	0
0	119119119119	116116116116	1111111111	106106106	102102102	100	119119119119	116116116116	1111111111	106106106	102102102	100
1	114111109106	111109107105	105103102	10110098	989786	94	114111109106	111109107105	105103102	10110098	989786	94
2	10810410097	1061029895	999693	969391	939189	88	10810410097	1061029895	999693	969391	939189	88
3	103979289	101969188	939087	918885	898684	82	103979289	101969188	939087	918885	898684	82
4	99918682	97908582	888481	868380	848179	77	99918682	97908582	888481	868380	848179	77
5	94868177	92858076	847976	827875	807774	73	94868177	92858076	847976	827875	807774	73
6	90827672	89817672	797571	787471	777370	69	90827672	89817672	797571	787471	777370	69
7	86777268	85777268	767167	747067	737067	65	86777268	85777268	767167	747067	737067	65
8	83746864	81736864	726764	716764	706663	62	83746864	81736864	726764	716764	706663	62
9	79706561	78706561	696461	686461	676361	59	79706561	78706561	696461	686461	676361	59
10	76676258	75676258	666158	656158	656158	57	76676258	75676258	666158	656158	656158	57

Zonal Lumen

ZONE	LUMENS	%FIXT
0-30	457	73.3
0-40	553	88.6
0-60	614	98.4
0-90	624	100.0
90-120	0	0.0
90-130	0	0.0
90-150	0	0.0
90-180	0	0.0
0-180	624	100.0

305 mm (1 ft), 15° x 30° beam angle

Lumens	Efficacy
673	33.7

Polar Candela Distribution

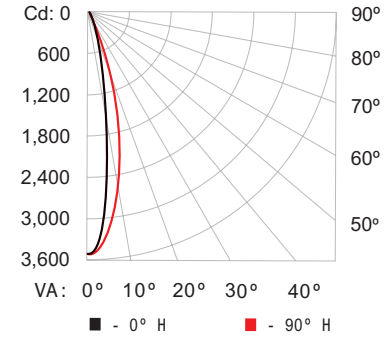

	0.0	22.5	45.0	67.5	90.0
0	3522	3522	3522	3522	3522
5	2794	2857	3019	3184	3255
15	548	625	892	1355	1646
25	75	88	142	280	415
35	19	21	28	48	68
45	9	10	11	15	18
55	6	6	6	8	9
65	4	4	4	5	5
75	2	2	2	2	2
85	1	1	1	1	0
90	0	0	0	0	0

Illuminance at Distance

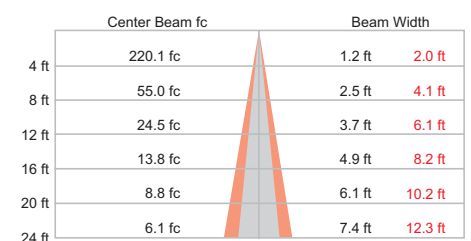

59 ft (18 m) 1 fc maximum distance
■ Vert. Spread: 17.4° ■ Horiz. Spread: 28.7°

Coefficients Of Utilization - Zonal Cavity Method

RC	Effective Floor Cavity Reflectance: 20%											
	80	70	50	30	10	0	80	70	50	30	10	0
RW	70	50	30	10	0	0	70	50	30	10	0	0
0	119119119119	116116116116	1111111111	106106106	102102102	100	119119119119	116116116116	1111111111	106106106	102102102	100
1	115113111109	11211109107	107105104	103102101	1009898	96	115113111109	11211109107	107105104	103102101	1009898	96
2	111107104102	109106103100	10210098	1009896	979594	93	111107104102	109106103100	10210098	1009896	979594	93
3	1071039996	1061019895	999694	969492	949291	90	1071039996	1061019895	999694	969492	949291	90
4	104989491	102979491	959290	949189	929088	87	104989491	102979491	959290	949189	929088	87
5	101959187	99949087	928986	918886	898785	84	101959187	99949087	928986	918886	898785	84
6	98928784	97918784	908683	888583	878482	81	98928784	97918784	908683	888583	878482	81
7	95898481	94888481	878381	868380	858280	79	95898481	94888481	878381	868380	858280	79
8	93868279	92858179	858178	848078	838078	77	93868279	92858179	858178	848078	838078	77
9	90837977	89837976	827876	827876	817876	75	90837977	89837976	827876	827876	817876	75
10	88817774	87817774	807774	807774	797674	73	88817774	87817774	807774	807774	797674	73

Zonal Lumen

ZONE	LUMENS
------	--------

305 mm (1 ft), 30° x 60° beam angle

Lumens	Efficacy
658	33.6

Polar Candela Distribution

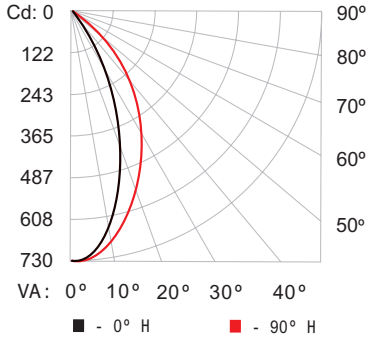

	0.0	22.5	45.0	67.5	90.0
0	725	725	725	725	725
5	702	703	707	710	711
15	527	538	570	602	617
25	300	320	379	447	482
35	115	134	194	284	333
45	36	42	72	140	187
55	16	17	24	52	80
65	9	9	11	17	27
75	3	4	4	6	8
85	2	2	2	1	2
90	1	1	1	1	0

Illuminance at Distance

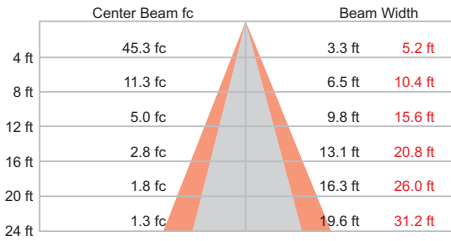

26 ft (7.9 m) Vert. Spread: 44.4°
1 fc maximum distance Horiz. Spread: 62.6°

Coefficients Of Utilization - Zonal Cavity Method

Effective Floor Cavity Reflectance: 20%

RC	80	70	50	30	10	0
0	119119119119	116116116116	1111111111	106106106	102102102	100
1	113110107104	110107105103	10310199	1009896	969594	92
2	1061019692	104999591	969289	939087	908886	84
3	100938783	98928682	898481	868380	848178	77
4	94868075	93857975	837874	817673	797572	70
5	89807369	87797368	777268	757167	747066	65
6	84746863	83746763	726762	716662	696562	60
7	80706358	78696358	676258	666158	656157	56
8	75655954	74655854	635854	625754	615753	52
9	72615551	70615551	605450	595450	585350	48
10	68585247	67575147	565147	565147	555047	45

Zonal Lumen

ZONE	LUMENS	%FIXT
0- 30	400	60.7
0- 40	531	80.7
0- 60	636	96.6
0- 90	657	99.9
90-120	1	0.1
90-130	1	0.1
90-150	1	0.1
90-180	1	0.1
0-180	658	100.0

For lux multiply fc by 10.7

305 mm (1 ft), 60° x 30° beam angle

Lumens	Efficacy
658	33.9

Polar Candela Distribution

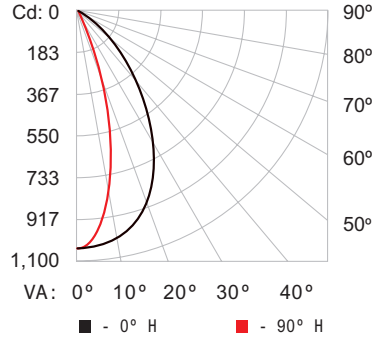

	0.0	22.5	45.0	67.5	90.0
0	1020	1020	1020	1020	1020
5	1012	1001	977	951	941
15	934	844	665	529	482
25	772	570	295	167	135
35	523	284	91	43	35
45	255	102	29	17	16
55	86	33	13	11	11
65	23	12	8	7	7
75	6	4	3	3	3
85	3	2	1	1	1
90	1	1	1	0	0

Illuminance at Distance

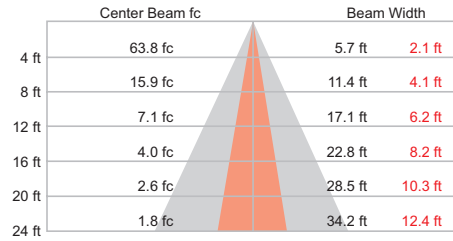

32 ft (9.8 m) Vert. Spread: 70.9°
1 fc maximum distance Horiz. Spread: 28.9°

Coefficients Of Utilization - Zonal Cavity Method

Effective Floor Cavity Reflectance: 20%

RC	80	70	50	30	10	0
0	119119119119	116116116116	1111111111	106106106	102102102	100
1	113110108105	111108106104	104102100	1009997	979695	93
2	1071029894	1051009793	979491	949289	918987	86
3	102959086	100948985	918784	888582	868381	79
4	96898379	95878278	858177	837976	817875	74
5	92837773	90827672	807572	787471	777370	69
6	87787267	85777167	767067	747066	736966	64
7	83736763	81736763	716662	706662	696562	60
8	79696359	78696359	686259	676258	666158	57
9	75666056	74655956	645955	635855	625855	54
10	72625653	71625652	615652	605552	595552	51

Zonal Lumen

ZONE	LUMENS	%FIXT
0- 30	450	68.4
0- 40	560	85.2
0- 60	641	97.5
0- 90	657	99.9
90-120	0	0.1
90-130	0	0.1
90-150	0	0.1
90-180	0	0.1
0-180	658	100.0

Photometrics/iW Graze QLX Powercore 5W

Photometric data is based on test results from an independent NIST traceable testing lab. IES data is available at www.philipscolorkinetics.com/support/ies.

305 mm (1 ft), 9° x 9° beam angle

Lumens	Efficacy
189	20.9

Polar Candela Distribution

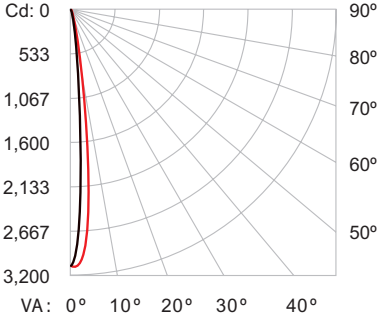

	0	25	45	70	90
0	985	985	985	985	985
5	741	761	808	869	890
15	152	181	250	395	455
25	21	28	47	97	127
35	5	6	9	18	21
45	2	3	3	5	5
55	2	2	2	2	3
65	1	1	1	1	2
75	1	1	1	1	1
85	0	0	0	0	0
90	0	0	0	0	0

Illuminance at Distance

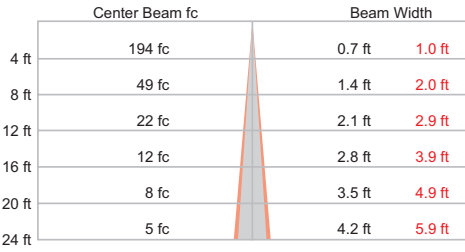

55.7 ft (17.0 m) 1 fc maximum distance
 ■ Vert. Spread: 10.0° ■ Horiz. Spread: 13.9°

Coefficients Of Utilization - Zonal Cavity Method

RCC %:	Effective Floor Cavity Reflectance: 20%														
	80	70	50	30	10	0	80	70	50	30	10	0			
RW %:	70	50	30	0	70	50	30	0	50	30	20	50	30	20	0
RCR:	0	119	119	119	119	119	119	119	119	119	119	119	119	119	119
1	118	114	112	111	111	111	111	111	111	111	111	111	111	111	111
2	113	110	107	105	111	108	106	97	105	103	102	102	101	100	98
3	110	107	104	101	109	105	103	95	103	101	99	97	99	97	96
4	108	104	101	98	107	103	100	94	101	98	97	99	97	95	97
5	106	101	98	96	105	100	98	93	99	96	95	98	95	94	93
6	104	99	96	94	103	99	96	91	97	95	93	96	94	92	91
7	102	97	94	92	101	97	94	90	96	93	91	95	93	91	90
8	101	96	93	91	100	95	92	89	94	92	90	94	91	90	89
9	99	94	91	89	98	94	91	88	93	91	89	93	90	89	88
10	98	93	90	88	97	93	90	87	92	90	88	91	89	88	87

Zonal Lumen

Zone	Lumens	% Fixture
0 - 60	190.0	99.4 %
60 - 90	0.9	0.5 %
0 - 90	188.6	100.0 %

305 mm (1 ft), 10° x 60° beam angle

Lumens	Efficacy
189	20.7

Polar Candela Distribution

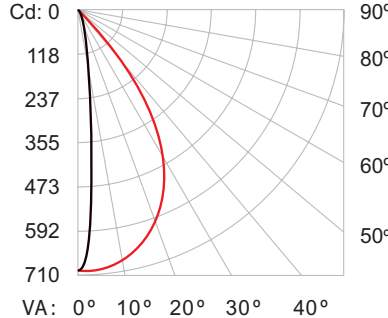

	0	25	45	70	90
0	701	701	701	701	701
5	330	368	469	637	695
15	38	52	92	314	649
25	6	7	20	127	533
35	2	3	5	54	335
45	1	2	3	19	135
55	1	1	1	6	32
65	1	1	1	2	8
75	0	0	0	1	3
85	0	0	0	0	0
90	0	0	0	0	0

Illuminance at Distance

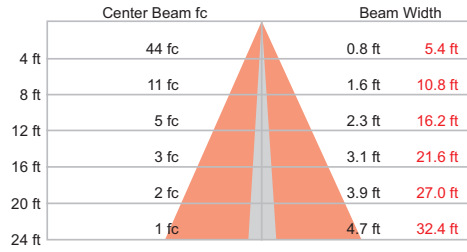

26.5 ft (8.1 m) 1 fc maximum distance
 ■ Vert. Spread: 11.1° ■ Horiz. Spread: 68.1°

Coefficients Of Utilization - Zonal Cavity Method

RCC %:	Effective Floor Cavity Reflectance: 20%														
	80	70	50	30	10	0	80	70	50	30	10	0			
RW %:	70	50	30	0	70	50	30	0	50	30	20	50	30	20	0
RCR:	0	114	111	109	107	111	109	107	105	103	102	101	100	99	98
1	114	111	109	107	111	109	107	94	105	103	102	101	100	99	98
2	109	104	100	97	106	102	99	89	99	96	94	96	94	92	91
3	104	97	93	89	102	96	92	84	93	90	87	91	88	86	84
4	99	92	87	83	97	91	86	79	88	84	81	87	83	80	78
5	94	87	81	77	93	86	81	75	84	80	76	82	79	76	75
6	90	82	77	73	89	81	76	71	80	75	72	78	74	71	70
7	86	78	72	69	85	77	72	67	76	71	68	75	71	68	66
8	83	74	69	65	82	74	69	64	73	68	65	72	67	64	63
9	80	71	66	62	79	70	65	61	70	65	62	69	64	61	60
10	77	68	63	59	76	67	62	58	67	62	59	66	62	59	57

Zonal Lumen

Zone	Lumens	% Fixture
0 - 60	185.9	98.6 %
60 - 90	2.6	1.4 %
0 - 90	188.6	100.0 %

305 mm (1 ft), 15° x 30° beam angle

Lumens	Efficacy
187	20.5

Polar Candela Distribution

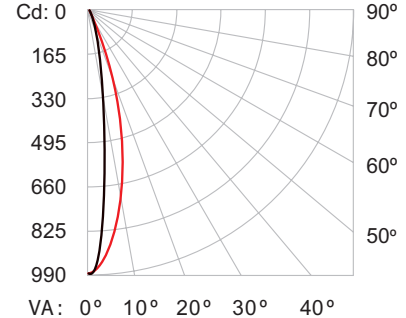

	0	25	45	70	90
0	985	985	985	985	985
5	741	761	808	869	890
15	152	181	250	395	455
25	21	28	47	97	127
35	5	6	9	18	21
45	2	3	3	5	5
55	2	2	2	2	3
65	1	1	1	1	2
75	1	1	1	1	1
85	0	0	0	0	0
90	0	0	0	0	0

Illuminance at Distance

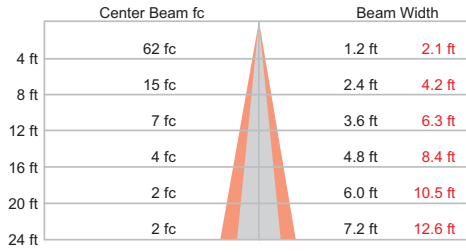

31.4 ft (9.6 m) 1 fc maximum distance
 ■ Vert. Spread: 17.1° ■ Horiz. Spread: 29.4°

Coefficients Of Utilization - Zonal Cavity Method

RCC %:	Effective Floor Cavity Reflectance: 20%														
	80	70	50	30	10	0	80	70	50	30	10	0			
RW %:	70	50	30	0	70	50	30	0	50	30	20	50	30	20	0
RCR:	0	119	119	119	119	119	119	119	119	119	119	119	119	119	119
1	115	113	111	109	112	111	109	97	107	105	104	103	102	101	100
2	111	107	104	102	109	106	103	93	102	100	98	100	98	96	94
3	107	103	99	96	106	101	98	90	99	96	94	96	94	92	91
4	104	98	94	91	102	97	94	87	95	92	90	94	91	89	88
5	101	95	91	88	99	94	90	85	92	89	86	91	88	86	84
6	98	92	87	84	97	91	87	82	90	86	83	88	85	83	81
7	95	89	84	81	94	88	84	80	87	83	81	86	83	80	79
8	93	86	82	79	92	85	81	78	85	81	78	84	80	78	77
9	90	83	79	77	89	83	79	76	82	79	76	82	78	76	75
10	88	81	77	74	87	81	77	74	80	77	74	80	76	74	73

Zonal Lumen

Zone	Lumens	% Fixture
0 - 60	185.4	99.0 %
60 - 90	1.8	1.0 %
0 - 90	187.2	100.0 %

305 mm (1 ft), 30° x 60° beam angle

Lumens	Efficacy
188	20.6

Polar Candela Distribution

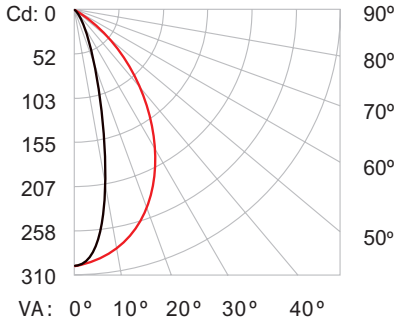

	0	25	45	70	90
0	299	299	299	299	299
5	280	282	288	294	294
15	135	154	194	254	268
25	33	45	82	181	223
35	8	11	23	99	159
45	4	5	7	38	84
55	3	3	3	11	31
65	2	2	2	4	9
75	1	1	1	1	2
85	0	0	0	0	0
90	0	0	0	0	0

Illuminance at Distance

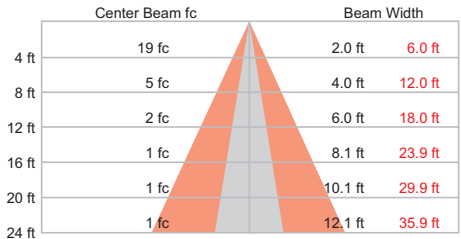

17.3 ft (5.3m) ■ Vert. Spread: 28.2°
 1 fc maximum distance ■ Horiz. Spread: 73.6°

Coefficients Of Utilization - Zonal Cavity Method

RCC %:	Effective Floor Cavity Reflectance: 20%											
	80	70	60	50	30	10	0	80	70	60		
RN %:	70	50	30	0	70	50	30	0	50	30	20	0
RCR:	0	119	119	119	116	116	116	100	111	111	111	106
	1	113	110	108	105	111	108	106	93	104	102	100
	2	107	102	98	94	105	100	97	87	97	94	91
	3	102	95	90	86	100	94	89	80	91	87	84
	4	96	89	83	79	95	87	82	75	85	81	77
	5	92	83	77	73	90	82	76	70	80	75	72
	6	87	78	72	67	85	77	71	66	76	70	67
	7	83	73	67	63	81	73	67	62	71	66	62
	8	79	69	63	59	78	69	63	58	68	62	59
	9	75	66	60	56	74	65	59	55	64	59	55
	10	72	62	56	53	71	62	56	52	61	56	52

Zonal Lumen

Zone	Lumens	% Fixture
0 - 60	183.4	97.6 %
60 - 90	4.4	2.4 %
0 - 90	187.8	100.0 %

305 mm (1 ft), 60° x 30° beam angle

Lumens	Efficacy
189	20.7

Polar Candela Distribution

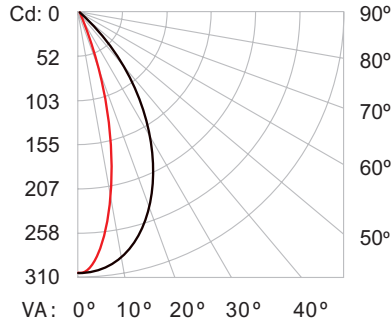

	0	25	45	70	90
0	305	305	305	305	305
5	300	295	287	278	277
15	271	238	193	154	145
25	212	151	88	51	45
35	130	70	28	13	11
45	56	24	9	5	5
55	17	8	4	3	3
65	4	3	2	2	2
75	1	1	1	1	1
85	1	0	0	0	0
90	0	0	0	0	0

Illuminance at Distance

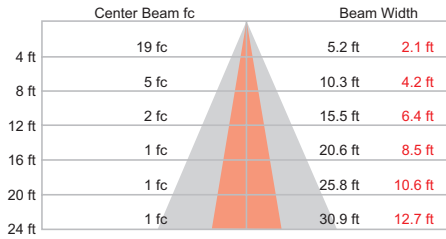

17.3 ft (5.3m) ■ Vert. Spread: 65.6°
 1 fc maximum distance ■ Horiz. Spread: 29.7°

Coefficients Of Utilization - Zonal Cavity Method

RCC %:	Effective Floor Cavity Reflectance: 20%											
	80	70	60	50	30	10	0	80	70	60		
RN %:	70	50	30	0	70	50	30	0	50	30	20	0
RCR:	0	119	119	119	116	116	116	100	111	111	111	107
	1	113	111	108	106	111	108	106	94	104	103	101
	2	108	103	99	95	106	101	97	87	98	95	92
	3	102	96	91	87	100	94	90	81	92	88	85
	4	97	89	84	80	95	88	83	76	86	82	78
	5	92	84	78	74	91	83	77	71	81	76	73
	6	88	79	73	69	86	78	72	67	77	72	68
	7	84	74	68	64	82	74	68	63	72	67	64
	8	80	70	64	60	79	70	64	59	69	64	60
	9	76	67	61	57	75	66	61	56	65	60	57
	10	73	63	58	54	72	63	57	53	62	57	53

Zonal Lumen

Zone	Lumens	% Fixture
0 - 60	185.5	98.0 %
60 - 90	3.8	2.0 %
0 - 90	189.3	100.0 %

Photometrics/iW Graze EC Powercore

Photometric data is based on test results from an independent NIST traceable testing lab. IES data is available at www.philipscolorkinetics.com/support/ies.

305 mm (1 ft), 90° x 90° beam angle

Lumens	Efficacy
412	29.6

Polar Candela Distribution

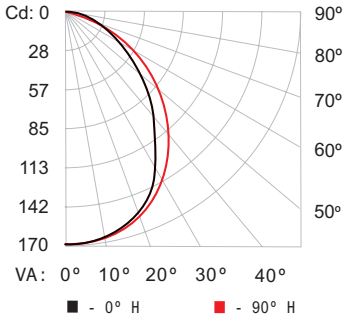

	0.0	22.5	45.0	67.5	90.0
0	169	169	169	169	169
5	169	169	169	169	169
15	161	162	162	162	162
25	144	145	147	148	149
35	112	115	123	127	127
45	84	85	91	99	101
55	54	56	62	69	72
65	36	35	37	42	44
75	24	23	21	21	21
85	16	14	10	7	4
90	13	11	7	3	0

Illuminance at Distance

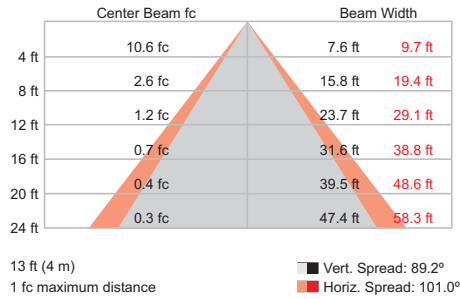

Coefficients Of Utilization - Zonal Cavity Method

Effective Floor Cavity Reflectance: 20%

RC	80			70			50			30			10			0		
RW	70	50	30	10	70	50	30	10	50	30	10	50	30	10	50	30	10	0
0	1191	191	119	119	1161	161	116	116	1101	101	10	105	105	105	101	101	101	98
1	1091	04	100	96	106	102	98	94	97	94	91	93	90	88	89	87	85	83
2	99	91	85	79	97	89	83	78	86	81	76	82	78	74	79	75	72	70
3	91	81	73	67	89	79	72	66	76	70	65	73	68	63	70	66	62	60
4	84	72	64	57	81	71	63	57	68	61	56	66	60	55	63	58	54	52
5	77	65	56	50	75	64	56	50	62	54	49	59	53	48	57	52	48	46
6	72	59	50	44	70	58	50	44	56	49	43	54	48	43	52	47	42	40
7	67	54	45	39	65	53	45	39	51	44	39	50	43	38	48	42	38	36
8	62	49	41	35	61	48	41	35	47	40	35	46	39	34	44	39	34	32
9	58	45	37	32	57	45	37	32	43	36	32	42	36	31	41	35	31	29
10	55	42	34	29	53	41	34	29	40	33	29	39	33	29	38	32	28	27

Zonal Lumen

ZONE	LUMENS	%FIXT
0 - 30	129	31.3
0 - 40	204	49.6
0 - 60	331	80.5
0 - 90	405	98.4
90 - 120	7	1.6
90 - 130	7	1.6
90 - 150	7	1.6
90 - 180	7	1.6
0 - 180	412	100.0

For lux multiply fc by 10.7

Specifications/iW Graze MX Powercore

Due to continuous improvements and innovations, specifications may change without notice.

Item	Beam Angle	305 mm (1 ft)	610 mm (2 ft)	914 mm (3 ft)	1219 mm (4 ft)	
Lumens*	9° x 9°	872	1744	2616	3488	
	10° x 60°	860	1720	2580	3440	
	15° x 30°	846	1692	2538	3384	
	30° x 60°	855	1710	2565	3420	
	60° x 30°	872	1744	2616	3488	
Item	Specification	305 mm (1 ft)	610 mm (2 ft)	914 mm (3 ft)	1219 mm (4 ft)	
Output	Color Temperature†	2700 K to 6500 K				
	LED Channels	2700 K/4000 K/6500 K				
	Efficacy (lm/W)	34.9 (9° x 9°)	34.0 (10° x 60°)	33.3 (15° x 30°)	33.4 (30° x 60°)	34.1 (60° x 30°)
	CRI	82				
	Lumen Maintenance‡	60,000 hours L70 @ 25° C 60,000 hours L70 @ 50° C 60,000 hours L50 @ 25° C 60,000 hours L50 @ 50° C				
Electrical	Input Voltage	100 to 277 VAC, auto-ranging, 50/60 Hz				
	Power Consumption	20 W max. at full output, steady state	40 W max. at full output, steady state	60 W max. at full output, steady state	80 W max. at full output, steady state	
Control	Interface	Data Enabler Pro (DMX or Ethernet)				
	Control System	Philips Color Kinetics full range of controllers, including Light System Manager, iPlayer 3, and ColorDial Pro, or third-party controllers				
Physical	Dimensions (Height x Width x Depth)	69 x 305 x 71 mm (2.7 x 12 x 2.8 in)	69 x 610 x 71 mm (2.7 x 24 x 2.8 in)	69 x 914 x 71 mm (2.7 x 36 x 2.8 in)	69 x 1219 x 71 mm (2.7 x 48 x 2.8 in)	
	Weight	1 kg (2.1 lb)	2.1 kg (4.6 lb)	3.2 kg (7.1 lb)	4.2 kg (9.3 lb)	
	Housing	Extruded anodized aluminium				
	Lens	Clear polycarbonate				
	Luminaire Connectors	Integral male/female waterproof connectors				
	Mounting	Multi-positional, constant torque locking hinges				
	Temperature	-40 to 50 °C (-40 to 122 °F) Operating -20 to 50 °C (-4 to 122 °F) Startup -40 to 80 °C (-40 to 176 °F) Storage				
	Mechanical Impact	IK10				
	Humidity	0 to 95%, non-condensing				
	Vibration Resistance♣	Complies with ANSI C136.31				
Luminaire Run Lengths	To calculate luminaire run lengths and total power consumption for your specific installation, download the Configuration Calculator from www.philipscolorkinetics.com/support/install_tool/					
Certification and Safety	Certification	UL/cUL, FCC Class A, CE, CQC, PSE, C-Tick				
	Environment	Dry/Damp/Wet Location, IP66				

* 305 mm (1 ft) lumen output measurements comply with IES LM-79-08 testing procedures. 610 mm (2 ft), 914 mm (3 ft), and 4 ft 1219 mm (4 ft) measurements are estimated based on the 305 mm (1 ft) measurements.



† Color temperatures conform to nominal CCTs as defined in ANSI Chromaticity Standard C78.377A.

‡ L70 = 70% lumen maintenance (when light output drops below 70% of initial output). L50 = 50% lumen maintenance (when light output drops below 50% of initial output). Ambient luminaire temperatures specified. Lumen maintenance calculations are based on lifetime prediction graphs supplied by LED source manufacturers. Calculations for white-light LED luminaires are based on measurements that comply with IES LM-80-08 testing procedures. Refer to www.philipscolorkinetics.com/support/appnotes/lm-80-08.pdf for more information.

♣ iW Graze 305 mm (1 ft) and 610 mm (2 ft) luminaire models conform to ANSI C136.31 roadway and area lighting luminaire vibration standards. ColorGraze 914 mm (3 ft) and 1219 mm (4 ft) luminaires can be customized for conformance. Please contact your Philips Color Kinetics Lighting Sales group for custom configurations.

CHROMACORE[®] | OPTIBIN[®] | POWERCORE[®]
CKTECHNOLOGY | CKTECHNOLOGY | CKTECHNOLOGY

Specifications/iW Graze QLX Powercore

Due to continuous improvements and innovations, specifications may change without notice.

Item	Beam Angle	305 mm (1 ft)	610 mm (2 ft)	914 mm (3 ft)	1219 mm (4 ft)
Lumens*	9° x 9°	661	1322	1983	2644
	10° x 60°	624	1248	1872	2496
	15° x 30°	673	1346	2019	2692
	30° x 60°	658	1316	1974	2632
	60° x 30°	658	1316	1974	2632

Item	Specification	305 mm (1 ft)	610 mm (2 ft)	914 mm (3 ft)	1219 mm (4 ft)	
Output	Color Temperature†	2700 K to 6500 K				
	LED Channels	2700 K/4000 K/6500 K				
	Efficacy (lm/W)	33.7 (9° x 9°)	31.5 (10° x 60°)	33.7 (15° x 30°)	33.6 (30° x 60°)	33.9 (60° x 30°)
	CRI	83				
	Lumen Maintenance‡	60,000 hours L70 @ 25° C 60,000 hours L70 @ 50° C 60,000 hours L50 @ 25° C 60,000 hours L50 @ 50° C				
Electrical	Input Voltage	100 to 277 VAC, auto-ranging 50/60 Hz				
	Power Consumption	15 W max. at full output, steady state	30 W max. at full output, steady state	45 W max. at full output, steady state	60 W max. at full output, steady state	
Control	Interface	Data Enabler Pro (DMX or Ethernet)				
	Control System	Philips Color Kinetics full range of controllers, including Light System Manager, iPlayer 3, and ColorDial Pro, or third-party controllers				
Physical	Dimensions (Height x Width x Depth)	69 x 305 x 71 mm (2.7 x 12 x 2.8 in)	69 x 610 x 71 mm (2.7 x 24 x 2.8 in)	69 x 914 x 71 mm (2.7 x 36 x 2.8 in)	69 x 1219 x 71 mm (2.7 x 48 x 2.8 in)	
	Weight	1 kg (2.1 lb)	2.1 kg (4.6 lb)	3.2 kg (7.1 lb)	4.2 kg (9.3 lb)	
	Housing	Extruded anodized aluminium				
	Lens	Clear polycarbonate				
	Luminaire Connectors	Integral male/female waterproof connectors				
	Mounting	Multi-positional, constant torque locking hinges				
	Temperature	-40 to 50 °C (-40 to 122 °F) Operating -20 to 50 °C (-4 to 122 °F) Startup -40 to 80 °C (-40 to 176 °F) Storage				
	Mechanical Impact	IK10				
	Humidity	0 to 95%, non-condensing				
	Vibration Resistance♣	Complies with ANSI C136.31				
	Luminaire Run Lengths	To calculate luminaire run lengths and total power consumption for your specific installation, download the Configuration Calculator from www.philipscolorkinetics.com/support/install_tool/				
Certification and Safety	Certification	UL/cUL, FCC Class A, CE, PSE, CQC, C-Tick				
	Environment	Dry/Damp/Wet Location, IP66				

* 305 mm (1 ft) lumen output measurements comply with IES LM-79-08 testing procedures. 610 mm (2 ft), 914 mm (3 ft), and 1219 mm (4 ft) measurements are estimated based on the 305 mm (1 ft) measurements.



† Color temperatures conform to nominal CCTs as defined in ANSI Chromaticity Standard C78.377A.

‡ L70 = 70% lumen maintenance (when light output drops below 70% of initial output). L50 = 50% lumen maintenance (when light output drops below 50% of initial output). Ambient luminaire temperatures specified. Lumen maintenance calculations are based on lifetime prediction graphs supplied by LED source manufacturers. Calculations for white-light LED luminaires are based on measurements that comply with IES LM-80-08 testing procedures. Refer to www.philipscolorkinetics.com/support/appnotes/lm-80-08.pdf for more information.

♣ iWGraze 305 mm (1 ft) and 610 mm (2 ft) luminaire models conform to ANSI C136.31 roadway and area lighting luminaire vibration standards. ColorGraze 914 mm (3 ft) and 1219 mm (4 ft) luminaires can be customized for conformance. Please contact your Philips Color Kinetics Lighting Sales group for custom configurations.

CHROMACORE[®] | OPTIBIN[®] | POWERCORE[®]
CKTECHNOLOGY | CKTECHNOLOGY | CKTECHNOLOGY

Specifications/iW Graze QLX Powercore 5W

Due to continuous improvements and innovations, specifications may change without notice.

Item	Beam Angle	305 mm (1 ft)	610 mm (2 ft)	914 mm (3 ft)	1219 mm (4 ft)	
Lumens*	9° x 9°	189	378	567	756	
	10° x 60°	189	378	567	756	
	15° x 30°	187	374	561	748	
	30° x 60°	188	376	564	752	
	60° x 30°	189	378	567	756	
Item	Specification	305 mm (1 ft)	610 mm (2 ft)	914 mm (3 ft)	1219 mm (4 ft)	
Output	Color Temperature†	2700 K to 6500 K				
	LED Channels	2700 K/4000 K/6500 K				
	Efficacy (lm/W)	20.9 (9° x 9°)	20.7 (10° x 60°)	20.5 (15° x 30°)	20.6 (30° x 60°)	20.7 (60° x 30°)
	CRI	82				
	Lumen Maintenance‡	60,000 hours L70 @ 25° C 60,000 hours L70 @ 50° C 60,000 hours L50 @ 25° C 60,000 hours L50 @ 50° C				
Electrical	Input Voltage	100 to 277 VAC, auto-ranging, 50/60 Hz				
	Power Consumption	5 W max. at full output, steady state	10 W max. at full output, steady state	15 W max. at full output, steady state	20 W max. at full output, steady state	
Control	Interface	Data Enabler Pro (DMX or Ethernet)				
	Control System	Philips Color Kinetics full range of controllers, including Light System Manager, iPlayer 3, and ColorDial Pro, or third-party controllers				
Physical	Dimensions (Height x Width x Depth)	2.7 x 12 x 2.8 in (69 x 305 x 71 mm)	2.7 x 24 x 2.8 in (69 x 610 x 71 mm)	2.7 x 36 x 2.8 in (69 x 914 x 71 mm)	2.7 x 48 x 2.8 in (69 x 1219 x 71 mm)	
	Weight	1 kg (2.1 lb)	2.1 kg (4.6 lb)	3.2 kg (7.1 lb)	4.2 kg (9.3 lb)	
	Housing	Extruded anodized aluminium				
	Lens	Clear polycarbonate				
	Luminaire Connectors	Integral male/female waterproof connectors				
	Mounting	Multi-positional, constant torque locking hinges				
	Temperature	-40 to 50 °C (-40 to 122 °F) Operating -20 to 50 °C (-4 to 122 °F) Startup -40 to 80 °C (-40 to 176 °F) Storage				
	Mechanical Impact	IK10				
	Humidity	0 to 95%, non-condensing				
	Vibration Resistance♣	Complies with ANSI C136.31				
	Luminaire Run Lengths	To calculate luminaire run lengths and total power consumption for your specific installation, download the Configuration Calculator from www.philipscolorkinetics.com/support/install_tool/				
	Certification and Safety	Certification	UL/cUL, FCC Class A, CE, CQC, PSE, C-Tick			
		Environment	Dry/Damp/Wet Location, IP66			

* 305 mm (1 ft) lumen output measurements comply with IES LM-79-08 testing procedures. 610 mm (2 ft), 914 mm (3 ft), and 1219 mm (4 ft) measurements are estimated based on the 305 mm (1 ft) measurements.



† Color temperatures conform to nominal CCTs as defined in ANSI Chromaticity Standard C78.377A.

‡ L70 = 70% lumen maintenance (when light output drops below 70% of initial output). L50 = 50% lumen maintenance (when light output drops below 50% of initial output). Ambient luminaire temperatures specified. Lumen maintenance calculations are based on lifetime prediction graphs supplied by LED source manufacturers. Calculations for white-light LED luminaires are based on measurements that comply with IES LM-80-08 testing procedures. Refer to www.philipscolorkinetics.com/support/appnotes/lm-80-08.pdf for more information.

♣ iWGraze 305 mm (1 ft) and 610 mm (2 ft) luminaire models conform to ANSI C136.31 roadway and area lighting luminaire vibration standards. ColorGraze 914 mm (3 ft) and 1219 mm (4 ft) luminaires can be customized for conformance. Please contact your Philips Color Kinetics Lighting Sales group for custom configurations.

CHROMACORE[®] | OPTIBIN[®] | POWERCORE[®]
CKTECHNOLOGY | CKTECHNOLOGY | CKTECHNOLOGY

Specifications/iW Graze EC Powercore

Due to continuous improvements and innovations, specifications may change without notice.

Item	Specification	305 mm (1 ft)	610 mm (2 ft)	914 mm (3 ft)	1219 mm (4 ft)
Output	Beam Angle	90° x 90°			
	Color Temperature†	2700 K to 6500 K			
	LED Channels	2700 K/4000 K/6500 K			
	Lumens*	412	824	1236	1648
	Efficacy (lm/W)	29.6			
	CRI	82			
Electrical	Lumen Maintenance‡	60,000 hours L70 @ 25° C 60,000 hours L70 @ 50° C 60,000 hours L50 @ 25° C 60,000 hours L50 @ 50° C			
	Input Voltage	100 to 277 VAC, auto-ranging, 50/60 Hz			
Electrical	Power Consumption	10 W max. at full output, steady state	20 W max. at full output, steady state	30 W max. at full output, steady state	40 W max. at full output, steady state
	Interface	Data Enabler Pro (DMX or Ethernet)			
Control	Control System	Philips Color Kinetics full range of controllers, including Light System Manager, iPlayer 3, and ColorDial Pro, or third-party controllers			
Physical	Dimensions (Height x Width x Depth)	69 x 305 x 71 mm (2.7 x 12 x 2.8 in)	69 x 610 x 71 mm (2.7 x 24 x 2.8 in)	69 x 914 x 71 mm (2.7 x 36 x 2.8 in)	69 x 1219 x 71 mm (2.7 x 48 x 2.8 in)
	Weight	1 kg (2.1 lb)	2.1 kg (4.6 lb)	3.2 kg (7.1 lb)	4.2 kg (9.3 lb)
	Housing	Extruded anodized aluminium			
	Lens	Clear polycarbonate			
	Luminaire Connectors	Integral male/female waterproof connectors			
	Mounting	Multi-positional, constant torque locking hinges			
	Temperature	-40 to 50 °C (-40 to 122 °F) Operating -20 to 50 °C (-4 to 122 °F) Startup -40 to 80 °C (-40 to 176 °F) Storage			
	Mechanical Impact	IK08			
	Humidity	0 to 95%, non-condensing			
	Vibration Resistance♣	Complies with ANSI C136.31			
	Luminaire Run Lengths	To calculate luminaire run lengths and total power consumption for your specific installation, download the Configuration Calculator from www.philipscolorkinetics.com/support/install_tool/			
Certification and Safety	Certification	UL/cUL, FCC Class A, CE, CQC, PSE, C-Tick			
	Environment	Dry/Damp/Wet Location, IP66			

* 305 mm (1 ft) lumen output measurements comply with IES LM-79-08 testing procedures. 610 mm (2 ft), 914 mm (3 ft), and 1219 mm (4 ft) measurements are estimated based on the 305 mm (1 ft) measurements.



† Color temperatures conform to nominal CCTs as defined in ANSI Chromaticity Standard C78.377A.

‡ L70 = 70% lumen maintenance (when light output drops below 70% of initial output). L50 = 50% lumen maintenance (when light output drops below 50% of initial output). Ambient luminaire temperatures specified. Lumen maintenance calculations are based on lifetime prediction graphs supplied by LED source manufacturers. Calculations for white-light LED luminaires are based on measurements that comply with IES LM-80-08 testing procedures. Refer to www.philipscolorkinetics.com/support/appnotes/lm-80-08.pdf for more information.

♣ iWGraze 305 mm (1 ft) and 610 mm (2 ft) luminaire models conform to ANSI C136.31 roadway and area lighting luminaire vibration standards. ColorGraze 914 mm (3 ft) and 1219 mm (4 ft) luminaires can be customized for conformance. Please contact your Philips Color Kinetics Lighting Sales group for custom configurations.

Luminaires and Accessories

iW Graze Powercore luminaires are part of a complete system which includes:

- One or more Data Enabler Pro devices
- Any Philips controller, including Light System Manager, iPlayer 3, and ColorDial Pro, or a third-party controller
- Leader Cables to connect the first luminaire in each series to a Data Enabler Pro
- Optional Jumper Cables to add space between luminaires in a series, if necessary
- 3 + ground copper wire to connect Data Enabler Pro devices to a common junction box, if installing luminaires in parallel. Standard 2.05 mm (12 AWG) stranded wire is recommended.

Item	Beam Angle	Item Number	Philips 12NC
iW Graze MX Powercore 305 mm (1 ft)	9° x 9°	523-000079-00	910503703151
	10° x 60°	523-000079-01	910503703645
	15° x 30°	523-000079-02	910503703646
	30° x 60°	523-000079-03	910503703647
	60° x 30°	523-000079-04	910503703648
iW Graze MX Powercore 610 mm (2 ft)	9° x 9°	523-000079-05	910503703649
	10° x 60°	523-000079-06	910503703650
	15° x 30°	523-000079-07	910503703651
	30° x 60°	523-000079-08	910503703652
	60° x 30°	523-000079-09	910503703653
iW Graze MX Powercore 914 mm (3 ft)	9° x 9°	523-000079-10	910503703654
	10° x 60°	523-000079-11	910503703655
	15° x 30°	523-000079-12	910503703656
	30° x 60°	523-000079-13	910503703657
	60° x 30°	523-000079-14	910503703658
iW Graze MX Powercore 1219 mm (4 ft)	9° x 9°	523-000079-15	910503703659
	10° x 60°	523-000079-16	910503703660
	15° x 30°	523-000079-17	910503703661
	30° x 60°	523-000079-18	910503703662
	60° x 30°	523-000079-19	910503703663
iW Graze QLX Powercore 305 mm (1 ft)	9° x 9°	523-000079-20	910503703664
	10° x 60°	523-000079-21	910503703665
	15° x 30°	523-000079-22	910503703666
	30° x 60°	523-000079-23	910503703667
	60° x 30°	523-000079-24	910503703668
iW Graze QLX Powercore 610 mm (2 ft)	9° x 9°	523-000079-25	910503703669
	10° x 60°	523-000079-26	910503703670
	15° x 30°	523-000079-27	910503703671
	30° x 60°	523-000079-28	910503703672
	60° x 30°	523-000079-29	910503703673
iW Graze QLX Powercore 914 mm (3 ft)	9° x 9°	523-000079-30	910503703674
	10° x 60°	523-000079-31	910503703675
	15° x 30°	523-000079-32	910503703676
	30° x 60°	523-000079-33	910503703677
	60° x 30°	523-000079-34	910503703678
iW Graze QLX Powercore 1219 mm (4 ft)	9° x 9°	523-000079-35	910503703679
	10° x 60°	523-000079-36	910503703680
	15° x 30°	523-000079-37	910503703681
	30° x 60°	523-000079-38	910503703682
	60° x 30°	523-000079-39	910503703683

Use Item Number when ordering in North America.

Item	Beam Angle	Item Number	Philips 12NC
iW Graze QLX Powercore 5W 305 mm (1 ft)	9° x 9°	523-000085-00	910503704062
	10° x 60°	523-000085-01	910503703819
	15° x 30°	523-000085-02	910503703820
	30° x 60°	523-000085-03	910503703821
	60° x 30°	523-000085-04	910503703822
iW Graze QLX Powercore 5W 610 mm (2 ft)	9° x 9°	523-000085-05	910503703823
	10° x 60°	523-000085-06	910503703824
	15° x 30°	523-000085-07	910503703825
	30° x 60°	523-000085-08	910503703826
	60° x 30°	523-000085-09	910503703827
iW Graze QLX Powercore 5W 914 mm (3 ft)	9° x 9°	523-000085-10	910503703828
	10° x 60°	523-000085-11	910503703829
	15° x 30°	523-000085-12	910503703830
	30° x 60°	523-000085-13	910503703831
	60° x 30°	523-000085-14	910503703832
iW Graze QLX Powercore 5W 1219 mm (4 ft)	9° x 9°	523-000085-15	910503703833
	10° x 60°	523-000085-16	910503703834
	15° x 30°	523-000085-17	910503703835
	30° x 60°	523-000085-18	910503703836
	60° x 30°	523-000085-19	910503703837
iW Graze EC Powercore 305 mm (1 ft)	90° x 90°	523-000079-40	910503703684
iW Graze EC Powercore 610 mm (2 ft)	90° x 90°	523-000079-41	910503703685
iW Graze EC Powercore 914 mm (3 ft)	90° x 90°	523-000079-42	910503703686
iW Graze EC Powercore 1219 mm (4 ft)	90° x 90°	523-000079-43	910503703687

Use Item Number when ordering in North America.

Item	Type	Size	Item Number	Philips 12NC
Leader Cable with Terminator	UL/cUL	3 m (10 ft)	108-000055-03	910503704066
		15.2 m (50 ft)	108-000055-00	910503703137
	CE/PSE	3 m (10 ft)	108-000055-04	910503704067
		15.2 m (50 ft)	108-000055-01	910503704064
Jumper Cable	UL/cUL	End-to-End	108-000057-00	910503703139
		305 mm (1 ft)	108-000057-03	910503704076
		1.5 m (5 ft)	108-000057-06	910503704079
		3 m (10 ft)	108-000057-09	910503704082
	CE/PSE	End-to-End	108-000057-01	910503704074
		305 mm (1 ft)	108-000057-04	910503704077
		1.5 m (5 ft)	108-000057-07	910503704080
		3 m (10 ft)	108-000057-10	910503704083
Glare Shield		305 mm (1 ft)	120-000081-00	910503700745
		610 mm (2 ft)	120-000081-01	910503700746
		914 mm (3 ft)	120-000081-02	910503700747
		1219 mm (4 ft)	120-000081-03	910503700748
Additional Terminators		Quantity 10	120-000157-00	910503703142
Additional Hinge		Quantity 1	120-000098-00	910503700772
Data Enabler Pro		3/4 in/1/2 in NPT (U.S. trade size conduit)	106-000004-00	910503701210
		PG21/PG13 (metric size conduit)	106-000004-01	910503701211

Use Item Number when ordering in North America.

Dimensions

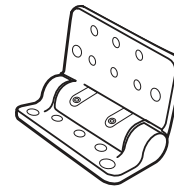
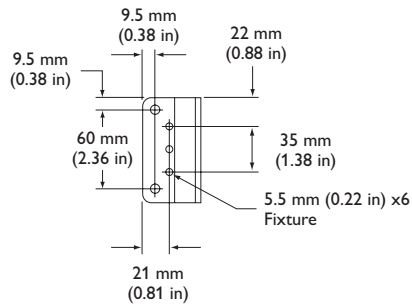
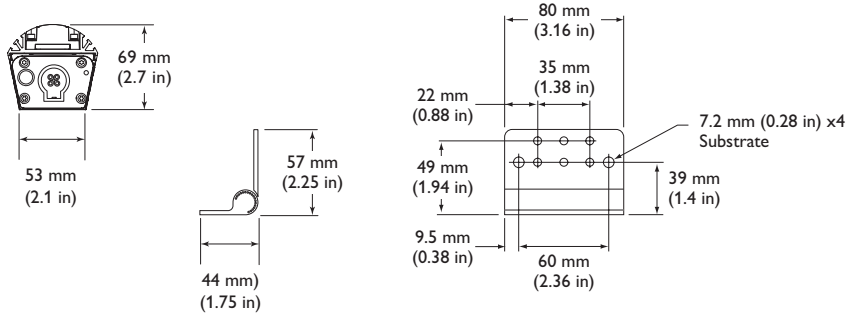
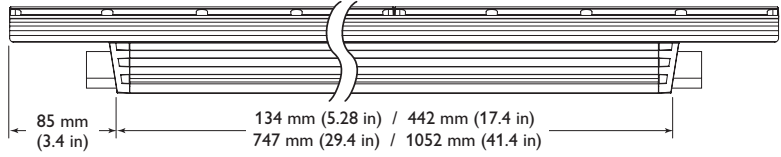
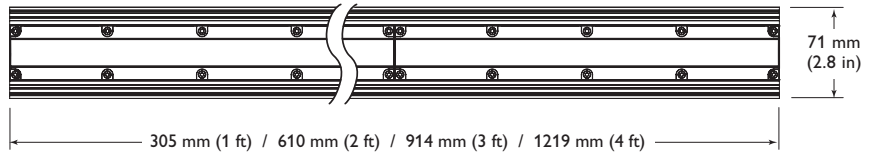
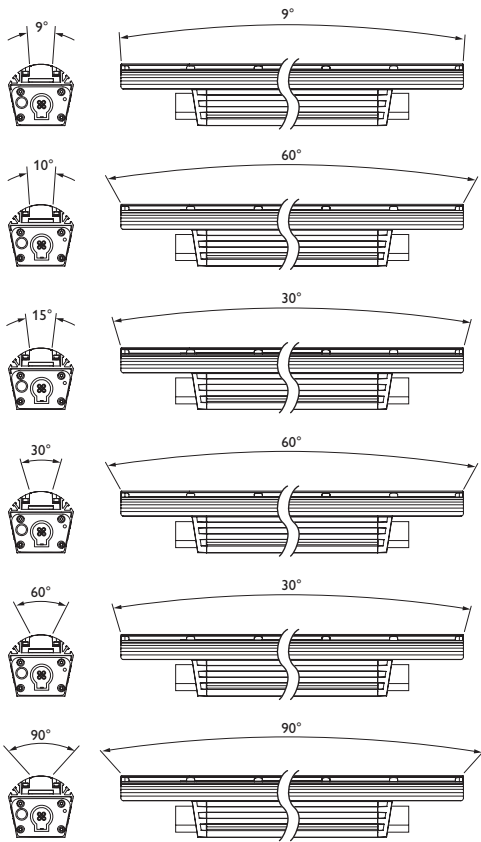

Installation

iW Graze Powercore offers dimmable, high-intensity white LED illumination with variable color temperature for wall-washing and grazing, enhancing architectural detail, both indoors and outdoors. Patented Powercore technology integrates LED power and data management within the luminaire, eases installation by eliminating the need for external power supplies.

Owner/User Responsibilities

It is the responsibility of the contractor, installer, purchaser, owner, and user to install, maintain, and operate iW Graze Powercore luminaires in such a manner as to comply with all applicable codes, state and local laws, ordinances, and regulations. Consult with the appropriate electrical inspector to ensure compliance.

Installing in Damp or Wet Locations

When installing in damp or wet locations, seal all Data Enabler Pro devices and junction boxes with electronics-grade RTV silicone sealant so that water or moisture cannot enter or accumulate in wiring compartments, cables, or other electrical parts. Use suitable outdoor-rated junction boxes when installing in damp or wet locations. Additionally, use gaskets, clamps, and other parts required for installation to comply with all applicable local and national codes.

Prepare for the Installation

1. Refer to the lighting design plan, architectural diagram, or other diagram that shows the physical layout of the installation to identify the locations of all switches, controllers, Data Enabler Pro devices, luminaires, and cables.
2. iW Graze Powercore luminaires can be installed in series or in parallel (wired to a common junction box). The maximum number of luminaires each Data Enabler Pro can support depends on specific configuration details such as luminaire length, luminaire spacing, circuit size, line voltage, and leader cable length. For more information, and for help calculating the number of luminaires your specific installation can support, download the Configuration Calculator from www.philipscolorkinetics.com/support/install_tool/, or consult Application Engineering Services at support@colorkinetics.com.

❄ Refer to the iW Graze Powercore Installation Instructions for specific warning and caution statements.

❄ Clean the lens with water and mild detergent using a soft cleaning cloth, and wipe dry. Because they will scratch, soften, pit, haze, yellow, mar, or crack the lens, do not use paper towels, abrasive cleaning products, window cleaners, or cleaning solutions containing chemicals such as ammonia, sodium hydroxide, and isopropyl alcohol.

In addition to maximum luminaire run lengths determined by the electrical configuration, each Data Enabler Pro imposes maximum run lengths based on data integrity. To ensure data integrity, maximum individual run lengths should not exceed 53.3 m (175 ft), and the total cable length per Data Enabler Pro should not exceed 122 m (400 ft).

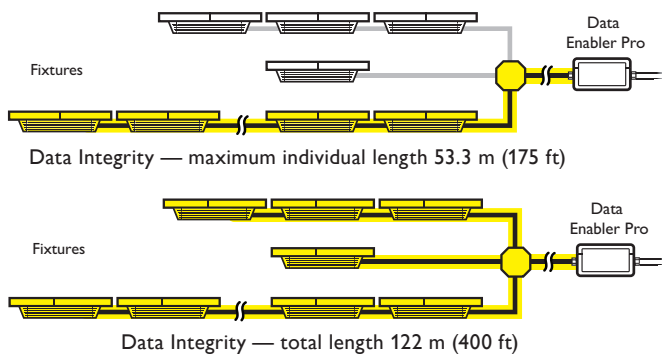

✳ Refer to the *Data Enabler Pro Installation Instructions* or *Product Guide* for guidelines on configuring and positioning the *Data Enabler Pro* in relation to the controller.

Start the Installation

1. Install all Data Enabler Pro devices, including any interfaces with controllers. Data Enabler Pro devices and external controllers send power and control signals to luminaires over Leader Cables. Jumper Cables are required to connect luminaires together in series.
2. Verify that all additional supporting equipment (switches, controllers) is in place.
3. Ensure that all additional parts and tools are available, including:
 - The included mounting hinges and hardware
 - 2 mm, 2.5 mm, and 4 mm hex key wrenches
 - 5 mm (1/4 in) socket cap fasteners, anchors, or screws for surface mounting
 - 3 + ground copper wire, as needed. Standard 2.05 mm (12 AWG) stranded wire is recommended.
 - Junction boxes, as needed, rated for your application. (Refer to the manufacturer's literature for additional items required for mounting or sealing.)
 - Electronics-grade room temperature vulcanizing (RTV) silicone sealant, as needed

Unpack and Prepare Luminaires

1. Carefully inspect the box containing iW Graze Powercore and the contents for any damage that may have occurred in transit.
2. iW Graze Powercore luminaires are addressable in 305 mm (1 ft) segments. This feature allows playback controllers to send unique light output data to each segment of each luminaire within your installation.

Each luminaire segment, or LED node, comes pre-programmed with a unique serial number. Each luminaire has from one to four serial numbers, depending on its length. As you unpack the luminaires, record the serial numbers in a layout grid (typically a spreadsheet or list) for easy reference and light addressing.

Included in the box

iW Graze Powercore luminaire
(1) or (2) Mounting hinges
(2) or (4) M5, 15 mm stainless steel hex bolts for hinge installation
Installation Instructions

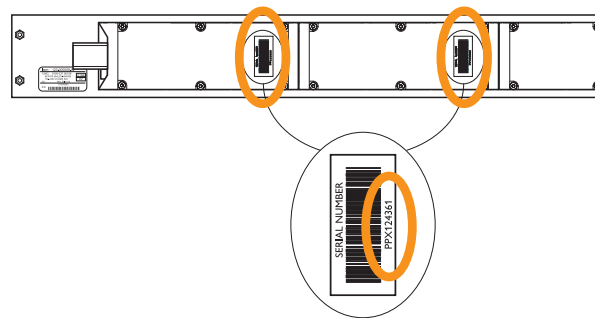
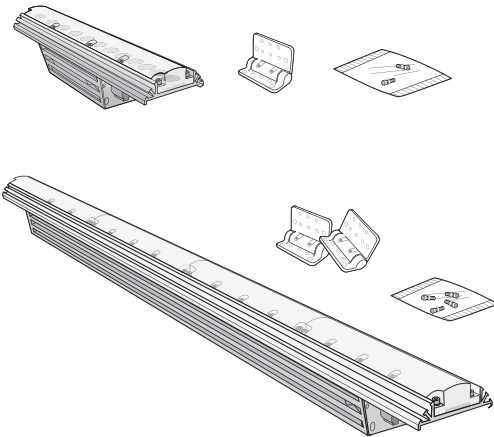

3. Assign each luminaire to a position in the lighting design plan.
4. To streamline installation and aid in light address programming, you can affix a weatherproof label identifying the order or placement in the installation to an inconspicuous location on each luminaire's housing.

Mount and Connect Luminaires

Make sure the power is OFF before mounting and connecting iW Graze Powercore luminaires.

iW Graze Powercore luminaires offer bulkhead connectors that accept the iW Graze Powercore pre-configured Leader and Jumper Cables. Because they have a male connector on one end of the luminaire and a female connector on the other end, iW Graze Powercore luminaires are directional, and must all be oriented in the same direction.

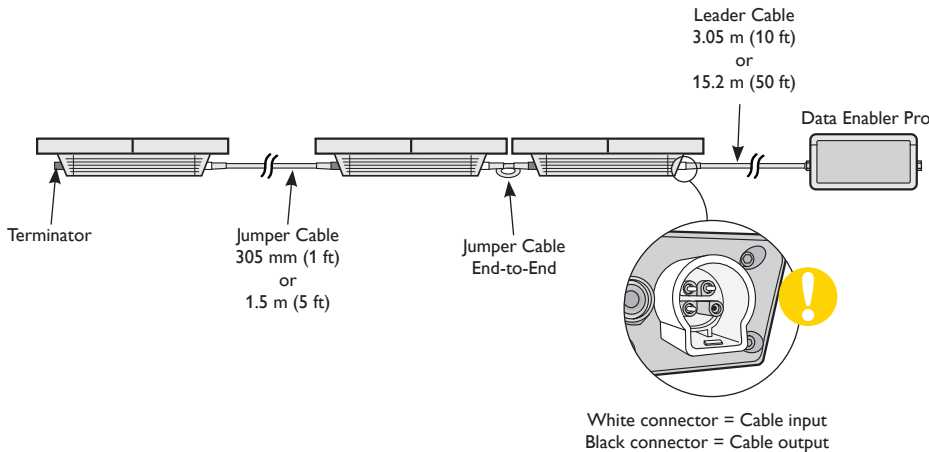

Mount Luminaires

- Using the included 4 mm hex hardware, attach two hinges to each luminaire. There are three possible methods for attaching hinges to the luminaires, each method offering differing degrees of swing radius and space-efficiency. Select the method most suitable for your application.

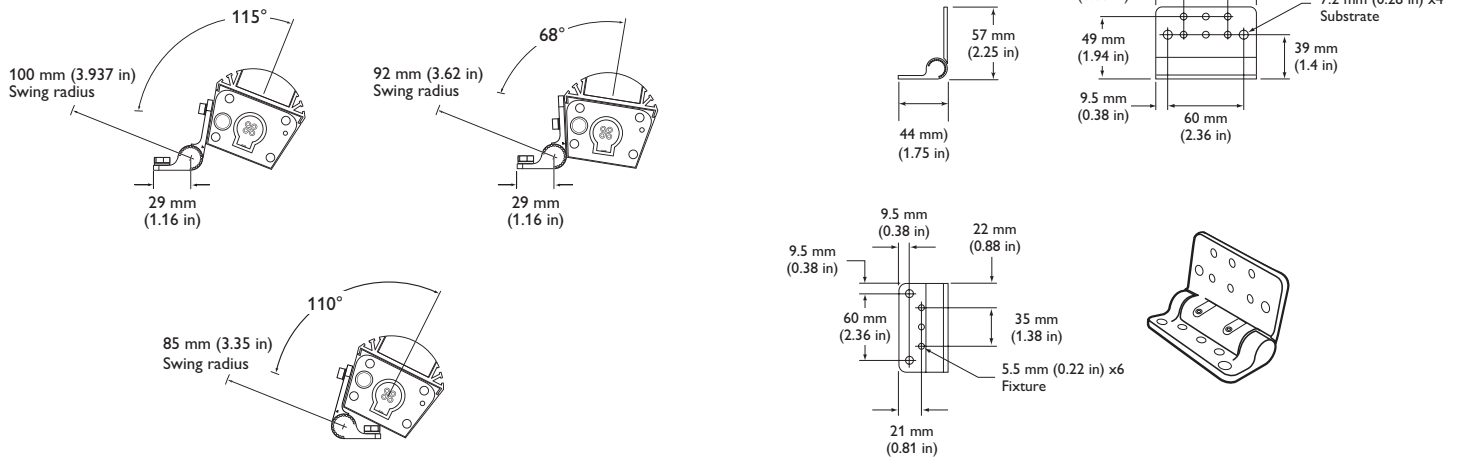

- If installing iW Graze Powercore luminaires in parallel, mount junction boxes in accordance with the lighting design plan.
- When installing a linear series of iW Graze Powercore luminaires, make sure that all luminaires are oriented in the same direction. The white connectors are for cable inputs, and the black connectors are for cable outputs. The Leader Cable connects to the male bulkhead connector on the first luminaire in each series.
- Rotate the luminaire hinge assemblies into the desired positions. For consistent position control, use the indicators on the side of each hinge knuckle for reference. Use a 2 mm hex key wrench to loosen the set screws, as needed.

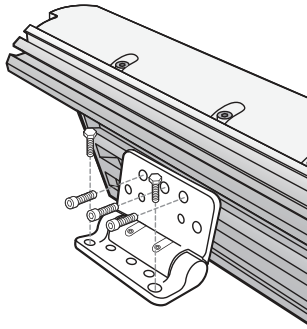

- To accommodate installation from various angles, each hinge has four set screws designed to lock the hinge position. All four, or only two, of the set screws may be used, depending on the mounting method and swing radius you select for the hinge. For example, if the hinge leaves are to be fully closed, the interior set screws may not be accessible.

Do not lock the hinges' positions at this time; the hinges have a built-in constant torque feature that allows temporary positioning. For optimal light output performance, aim and lock the hinges following installation.

Make Cable Connections

- Connect Leader Cables:

- If installing luminaires in series, run a 3 m (10 ft) or 15.2 m (50 ft) Leader Cable from a Data Enabler Pro device to the input side of the first luminaire in the series. Push the Leader Cable into the connector to lock it into place.
- If installing luminaires in parallel, run 3 + ground copper wire from a Data Enabler Pro device to a common junction box.

Run Leader Cables from the common junction box to the input side of the first luminaire in each series. Push the Leader Cables into the connectors to lock them into place.

Within the common junction box, use wire nuts to connect line, neutral, ground, and data wires. Tuck wire connections into the junction box.

Secure all junction box covers. If installing in a damp or wet location, seal all junction boxes and points of entry with contractor-grade RTV silicone sealant. Use gaskets, clamps, and other parts and fittings required to comply with local outdoor wiring codes.

- Connect all Jumper Cables between luminaires. Push the cable ends into the connectors to lock them into place.
- Insert a terminator into the output side of the last luminaire in each series. (Terminators are provided with the iW Graze Powercore Leader Cables.)

Minimum distance between luminaires

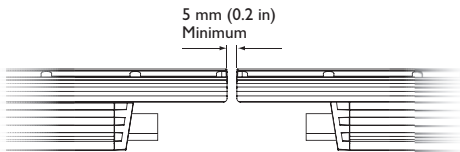

❁ Be sure to position luminaires close enough together so that Leader Cables and Jumper Cables are not stretched or taut when installed.

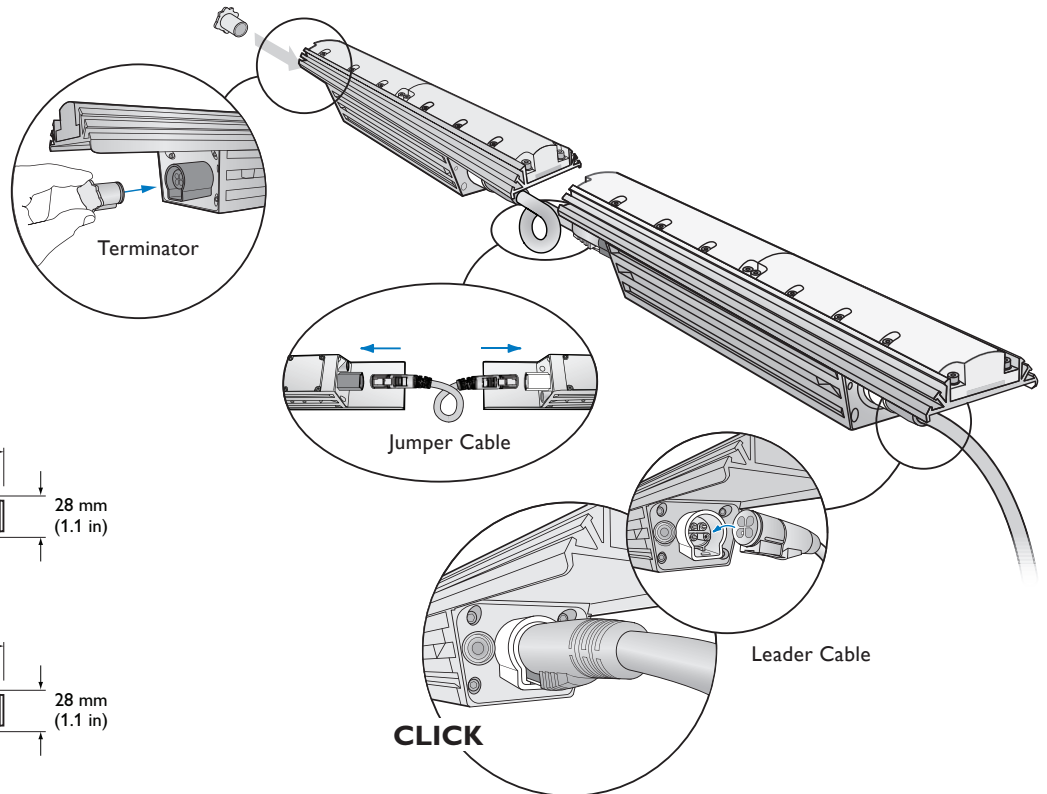

Leader Cable Connector Dimensions

UL/cUL

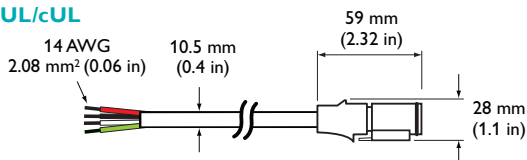

CE/PSE

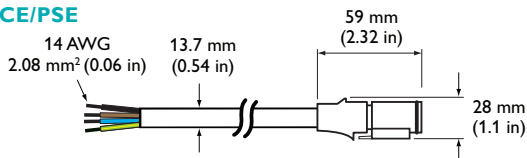

Make Power Connections

Once you've made all luminaire and junction box connections, connect the flying leads from a Leader Cable or 3 + ground wire from a common junction box to the 4-wire PC terminal connector block inside the Data Enabler Pro Housing.

Power/data output to luminaires

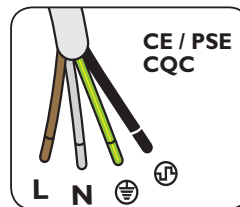
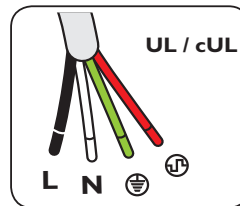
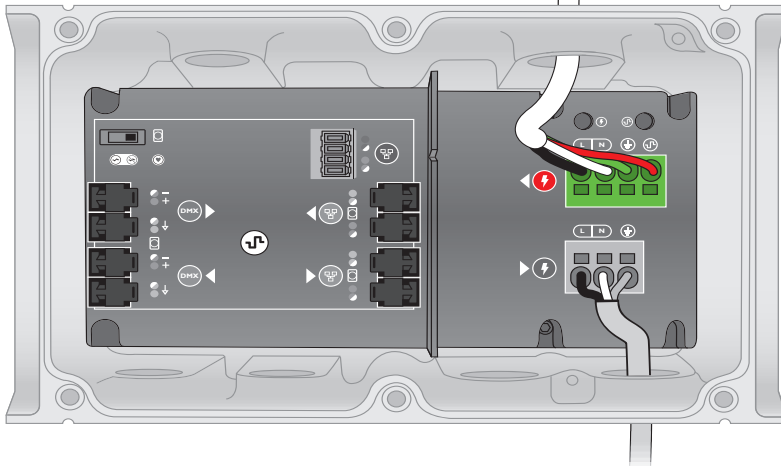

✳ Refer to the Data Enabler Pro Product Guide for comprehensive installation and configuration instructions. You can view or download the guide from www.philipscolorkinetics.com/ls/pds/dataenablerpro

Mains voltage output

Controlling iW Graze Powercore Luminaires

Philips Color Kinetics offers a number of control options for all iW Graze Powercore luminaires, from simple to complex.

iW Graze Powercore luminaires are addressable in 305 mm (1 ft) segments, or nodes. iW Graze Powercore luminaires have one, two, three, or four nodes, depending on luminaire length. Each node is identified by a unique serial number.

Displaying Fixed Light Output

For installations in which you want to manually adjust the brightness and color temperature of all luminaires in unison, use ColorDial Pro or iColor Keypad. With these controllers, no luminaire node addressing or configuration is necessary.

ColorDial Pro and iColor Keypad are Power-Over-Ethernet (PoE) devices that require a PoE switch, or a conventional Ethernet switch with a PoE injector. Refer to the ColorDial Pro or iColor Keypad documentation for details on how to install and use these controllers with iW Graze Powercore luminaires.

iW Graze Powercore has three LED channels, warm, neutral, and cool. By default, iW Graze Powercore is set to two-channel mode. In two-channel mode, luminaires automatically map two channels of data input to the three LED channels. Using QuickPlay Pro addressing and configuration software, you can also set iW Graze Powercore to operate in three-channel mode.

- In three-channel mode, use the Fixed Color effect in iColor Player or iColor Keypad, or the Fixed Color or Variable Color effect in ColorDial Pro.
- In two-channel mode, use the Fixed White effect in iColor Player, iColor Keypad, or ColorDial Pro.

Displaying Dynamic Light Output

For dynamic installations in which you want to display different light output on iW Graze Powercore luminaire nodes simultaneously, you must use an RGB-based DMX or Ethernet controller such as iColor Player, iPlayer 3, or Light System Manager. To support dynamic effects that automatically modify brightness and color temperature on individual luminaires nodes you must address and configure iW Graze Powercore as you would any color-changing (RGB) luminaire.

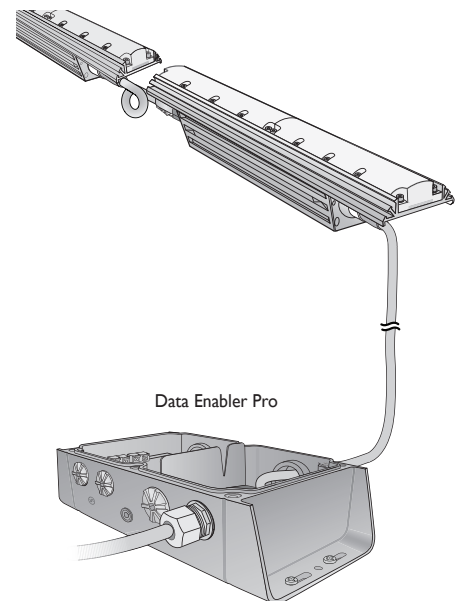

✳ You can address luminaires and switch between 8-bit mode and 16-bit mode using QuickPlay Pro. You can download QuickPlay Pro from www.philipscolorkinetics.com/support/addressing/

* You can download QuickPlay Pro from www.philipscolorkinetics.com/support/addressing.

* You will need the layout grid that you created when you recorded the serial numbers of the light luminaires in your installation.

iW Graze Powercore luminaires use DMX addresses to communicate with controllers. The number of DMX addresses each iW Graze Powercore luminaire requires depends on the luminaire's configuration.

Addressing iW Graze Powercore Luminaires

Make sure the power is ON before addressing and configuring luminaires.

You address and configure iW Graze Powercore luminaire nodes using QuickPlay Pro addressing and configuration software. Luminaire nodes are identified within QuickPlay Pro by serial number, so you will need the layout grid that you created when you recorded the serial numbers of your luminaire nodes during installation planning.

- In Ethernet installations, you can address and configure luminaire nodes using QuickPlay Pro with a computer connected to your lighting installation's network. QuickPlay Pro can automatically discover all of your luminaire nodes, controllers, and Data Enabler Pro devices for quick configuration.
- In DMX installations, you can address and configure luminaire nodes using QuickPlay Pro with iPlayer 3 or SmartJack Pro. You can manually enter luminaire node serial numbers, or you can import a spreadsheet listing each luminaire node's serial number and starting DMX address.

iW Graze Powercore luminaires operate in 8-bit mode by default. You can configure luminaires to operate in 16-bit mode, which increases resolution for smoother dimming and more precise control. In 8-bit mode, luminaire nodes use one DMX address per LED channel. In 16-bit mode, luminaire nodes use two DMX addresses per LED channel. The first DMX address corresponds to the "coarse" data for that channel, and the second corresponds to the "fine" data. By using double the number of DMX addresses, 16-bit mode increases resolution from 256 dimming steps to 65,536 (256 x 256) dimming steps.

You can address and configure iW Graze Powercore luminaire nodes in much the same way as you would address any RGB luminaire. Addressing differs depending on whether luminaires are in two-channel mode or three-channel mode:

- In three-channel mode, the red channel corresponds to the warm LEDs, the green channel corresponds to the neutral LEDs, and the blue channel corresponds to the cool LEDs.
- In two-channel mode, the red channel corresponds to the warm LEDs, the green channel corresponds to the cool LEDs, and the blue channel is not used.

Note that although the blue DMX channel is not used, it is *assigned*, so that each iW Graze Powercore luminaire node uses three DMX sequential addresses (or a multiple of three addresses), as in three-channel mode.

iW Graze Powercore luminaire nodes come factory-addressed with a starting DMX address of 1. For lighting designs where luminaires work in unison, all luminaire nodes can be assigned the same starting DMX address. Changes to the default starting DMX addresses are not necessary, but if nodes were previously readdressed for use in other installations, you must reset them. For light show designs that show different light output on different luminaire nodes simultaneously, you must assign unique DMX addresses to your nodes and sort them in a useful order.

LED Channels

Channel Mode	RGB	iW Graze Powercore
Three-Channel Mode	Red	Warm
	Green	Neutral
	Blue	Cool
Two-Channel Mode	Red	Warm
	Green	Cool
	Blue	Unused

The following table shows the DMX channel assignments per node for 8-bit and 16-bit iW Graze Powercore configurations, assuming a starting DMX address of 1.

DMX Channel Assignments Per Node: Two-Channel Mode

8-bit Mode	1		2		3	
	Warm		Cool		Unused	
16-Bit Mode	1	2	3	4	5	6
	Warm	Warm	Cool	Cool	Unused	Unused

DMX Channel Assignments Per Node: Three-Channel Mode

8-bit Mode	1		2		3	
	Warm		Neutral		Cool	
16-Bit Mode	1	2	3	4	5	6
	Warm	Warm	Neutral	Neutral	Cool	Cool

Setting Luminaire Dimming Curves

Dimming curves describe how slowly or quickly a luminaire dims at different levels of input. For finer control, iW Graze Powercore offers three different dimming curves for use in different situations and applications:

- **Normal**
The non-linear (gamma) dimming curve used in most Philips Color Kinetics LED lighting luminaires. iW Graze Powercore luminaires use the normal dimming curve by default.
- **Linear**
A dimming curve with a linear relationship between power input and DMX output.
- **Tungsten**
A non-linear dimming curve that emulates the dimming curve of incandescent lamps on a DMX dimmer. This curve offers the most control at low intensities.

Setting LED Transition Speed

Normally, LEDs react to DMX or other control data instantaneously. In some cases, you may want to slow down the reaction speed to achieve smoother transitions when the intensity of different LED channels changes. iW Graze Powercore offers five levels of decreasing LED transition speed, from Fast (instant snap changes) to Delay-4 (slowest transition speed).

Aim and Lock the Luminaires

Make sure power is ON before aiming luminaires.

Rotate the luminaires to achieve the optimal angle for light output. For consistent position control, use the indicators on the side of each hinge knuckle as reference.

For fine horizontal adjustment, you can change the position of the hinge mounting block located on the side of each luminaire. Loosen the set screw with a 2.5 mm hex key, slide the mounting block to the desired position, then tighten the set screw.

Once satisfied with luminaire angles and positioning, use a 2 mm hex key wrench to tighten the hinge position set screws and lock each hinge.

✳ Do not look directly into a luminaire when aiming and locking.

✳ The hinge position set screws have factory applied thread lock. Confirm the luminaire angle and positioning before locking each hinge.

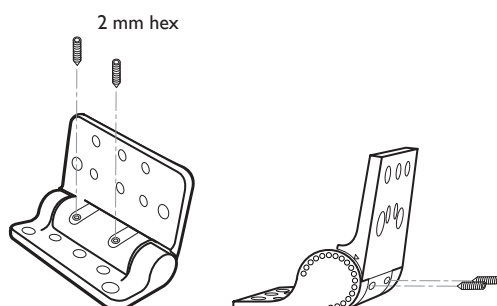

Attach Glare Shields (Optional)

Glare Shields, in 305 mm (1 ft), 610 mm (2 ft), 914 mm (3 ft), and 1.2 m (4 ft) lengths, can be inserted in the grooves in the iW Graze Powercore housing. Glare Shields block unwanted spill light, and can shield the light sources from being directly visible in certain mounting situations.

1. Insert the Glare Shield's triangular tab in the outer groove on the side of the iW Graze Powercore housing.

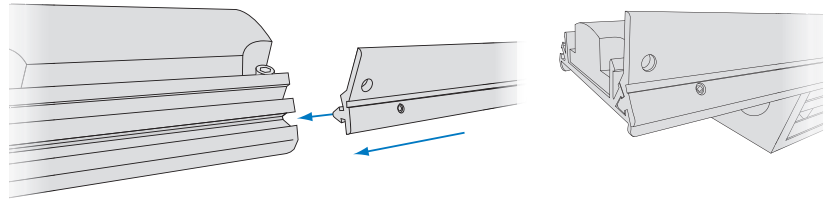

2. Using a hex wrench, tighten the locking screws to hold the Glare Shield in place.
3. (Optional) Attach a tether to the knockout in the Glare Shield, and affix the tether to a secure anchor point.
4. Using a small screwdriver, hand-tighten all set screws. Using a 1.5 mm hex wrench, torque the set screws to approximately 4 kgf/cm (3.5 in-lbs) to hold the Glare Shield in place.

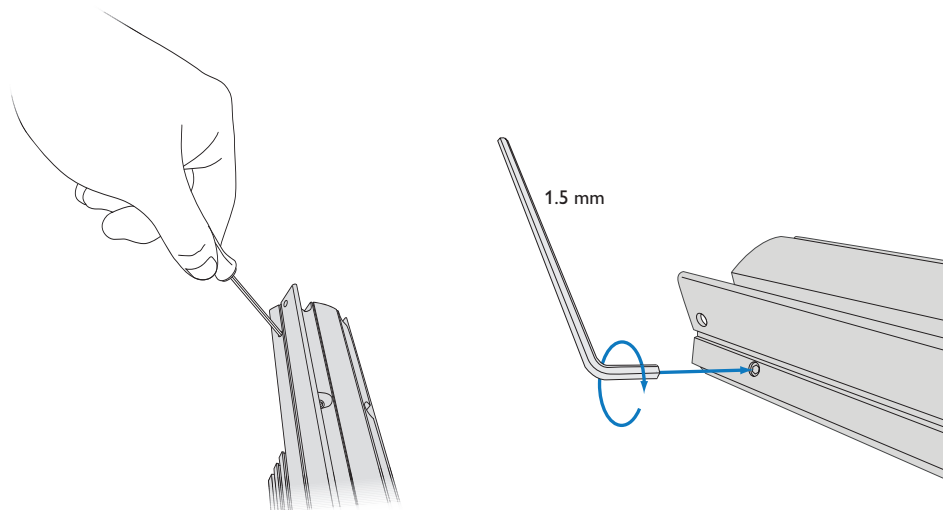

Copyright © 2017 Philips Lighting Holding B.V. All rights reserved.
Chromacore, Chromasic, CK, the CK logo, Color Kinetics, the Color Kinetics logo, ColorBlast, ColorBlaze, ColorBurst, ColorGraze, ColorPlay, ColorReach, iW Reach, eW Reach, DIMand, EssentialWhite, EvenBalance, eW, iColor, iColor Cove, IntelliWhite, iW, iPlayer, Optibin, Powercore, and PureStyle are either registered trademarks or trademarks of Philips Lighting Holding B.V. in the United States and/or other countries. All other brand or product names are trademarks or registered trademarks of their respective owners. Due to continuous improvements and innovations, specifications may change without notice.



Philips Color Kinetics
www.philips.com/colorkinetics