

PHILIPS ADVANCE

Metal
Halide
Lamp Ballast

Catalog Number 71A6592
For 1000W M47
60 Hz CWA
Status: Active

DIMENSIONS AND DATA

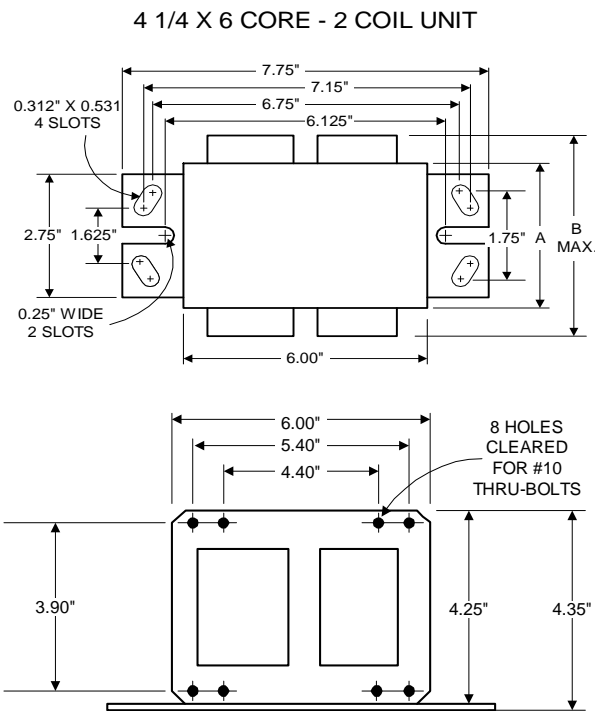

	120	208	240	277
INPUT VOLTS				
CIRCUIT TYPE	CWA			
POWER FACTOR (min)	90%			
REGULATION				
Line Volts	±10%			
Lamp Watts	±10%			
LINE CURRENT (Amps)				
Operating.....	9.00	5.20	4.50	3.90
Open Circuit.....	4.50	2.70	2.30	2.20
Starting.....	7.80	4.00	3.70	3.20
UL TEMPERATURE RATINGS				
Insulation Class	N(200°C)			
Coil Temperature Code	1029			
MIN. AMBIENT STARTING TEMP.	-20°F or -30°C			
NOM. OPEN CIRCUIT VOLTAGE	430			
INPUT VOLTAGE AT LAMP DROPOUT.....	84	146	168	194
INPUT WATTS	1080			
RECOMMENDED FUSE (Amps).....	20	15	10	10
CORE and COIL				
Dimension (A)	2.57			
Dimension (B)	4.50			
Weight (lbs.)	21			
Lead Lengths	12"			
CAPACITOR REQUIREMENT				
Microfarads	24.0			
Volts (min.)	480			
Fault Current Withstand (amps)				
60 Hz TEST PROCEDURES (Refer to Advance Test Procedure for HID Ballasts - Form 1270)				
High Potential Test (Volts)				
1 minute	2000			
2 seconds	2500			
Open Circuit Voltage Test (Volts)	385-475			
Short-Circuit Current Test (Amps)				
Secondary Current	5.20-6.40			
Input Current.....	5.60-8.60	3.20-4.80	2.80-4.30	2.40-3.60

Capacitor: MD2409-100

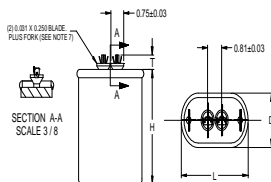

Capacitance: 24
Dia/Oval Dim: 1.75
Height: 3.9
Temp Rating: 90°C

Wiring Diagram:

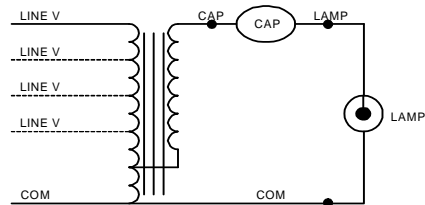

Fig. A

Ordering Information

Order Suffix

Description

Ignitor:

NA

This ballast does not require the use of an ignitor.

Data is based upon tests performed by Philips Lighting Electronic N.A. in a controlled environment and representative of relative performance. Actual performance can vary depending on operating conditions. Specifications are subject to change without notice.

Philips Lighting Electronic N.A.

10275 West Higgins Road · Rosemont, IL 60018 · Tel:800-322-2086 Fax:888-432-1882
Customer Support/ Technical Service:800-372-3331 · OEM Support: 866-915-5886

01/17/12