

PHILIPS ADVANCE

Metal
Halide
Lamp Ballast

Catalog Number 71A65A2
For 1000W M47
60 Hz CWA
Status: Active

DIMENSIONS AND DATA

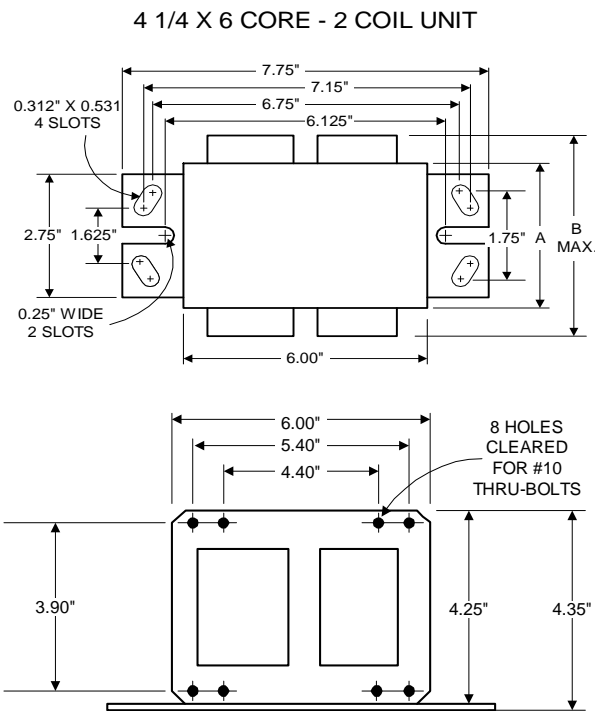

INPUT VOLTS	120	277	347		
CIRCUIT TYPE	CWA				
POWER FACTOR (min)	90%				
REGULATION					
Line Volts	±10%				
Lamp Watts	±10%				
LINE CURRENT (Amps)					
Operating.....	9.00	3.90	3.20		
Open Circuit.....	4.50	2.20	1.70		
Starting.....	7.80	3.20	2.50		
UL TEMPERATURE RATINGS					
Insulation Class	H(180°C)				
Coil Temperature Code	1029				
	D	C	C		
MIN. AMBIENT STARTING TEMP.	-20°F or -30°C				
NOM. OPEN CIRCUIT VOLTAGE	430				
INPUT VOLTAGE AT LAMP DROPOUT.....	84	194	243		
INPUT WATTS	1080				
RECOMMENDED FUSE (Amps).....	20	10	8		
CORE and COIL					
Dimension (A)	2.80				
Dimension (B)	4.50				
Weight (lbs.)	21				
Lead Lengths	12"				
CAPACITOR REQUIREMENT					
Microfarads	24.0				
Volts (min.)	480				
Fault Current Withstand (amps)					
60 Hz TEST PROCEDURES (Refer to Advance Test Procedure for HID Ballasts - Form 1270)					
High Potential Test (Volts)					
1 minute	2000				
2 seconds	2500				
Open Circuit Voltage Test (Volts)	385-475				
Short-Circuit Current Test (Amps)					
Secondary Current	5.20-6.40				
Input Current.....	4.80-7.30	2.00-3.10	1.60-2.60	-	-

Capacitor: MD2409-100

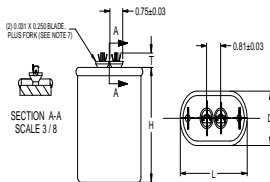

Capacitance: 24
Dia/Oval Dim: 1.75
Height: 3.9
Temp Rating: 90°C

Wiring Diagram:

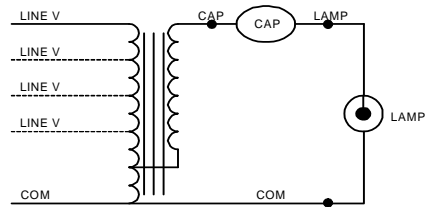

Fig. A

Ordering Information

Order Suffix	Description

Ignitor:

NA

This ballast does not require the use of an ignitor.

Data is based upon tests performed by Philips Lighting Electronic N.A. in a controlled environment and representative of relative performance. Actual performance can vary depending on operating conditions. Specifications are subject to change without notice.

Philips Lighting Electronic N.A.

10275 West Higgins Road · Rosemont, IL 60018 · Tel:800-322-2086 Fax:888-432-1882
Customer Support/ Technical Service:800-372-3331 · OEM Support: 866-915-5886

09/18/01