



# Xtreme drivers for maximum energy savings

## DynaVision Programmable Xtreme for CDMe

Highly reliable and flexible electronic drivers for MASTERColour CDMe MW lamps; designed to save on energy costs via integrated controls and to reduce maintenance costs thanks to 80,000 hour lifetime and integrated lightning protection. The DynaVision Programmable product family is the perfect basis for any sort of lighting management solution.

### Benefits

- Most efficient white-light system in the industry in its power range
- Designed to minimize maintenance cost in outdoor lighting
- No down-time due to calamities (storms, lightning strikes, etc.)
- Same energy consumption and smooth driving of the lamp regardless of fluctuations in the mains voltage

### Features

- Programmable by means of standard digital interface (DALI) and controllable via DALI protocol
- Integrates control options (DynaDimmer)
- Longest lifetime for electronic driver: 80,000 hours with minimum 90% survival at  $T_c = 80\text{ }^\circ\text{C}$
- Lightning protection 10 kV/5 kA
- Accurate lamp power stabilization of 95-97% over wide mains-voltage range of 180-300 V

# DynaVision Programmable Xtreme for CDMe

## Application

- High-bay retail
- Floodlighting
- Area and road lighting
- Offices and industry

## Versions

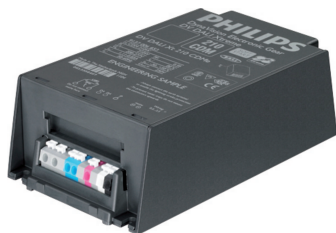

HID-DV PROG Xt CDMe/CPO

## Dimensional drawing

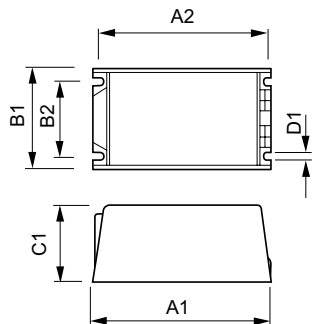

Product	D1	C1	A1	A2	B1	B2
HID-DV PROG Xt 210 CDMe/CPO C2 208-277V	4.8 mm	58.0 mm	169.0 mm	156.0 mm	100.0 mm	81.5 mm

