

# Long-lasting, reliable solution

## HID-HeavyDuty BSX for SOX

Encapsulated electromagnetic copper/iron ballasts for SOX and SOX-E lamps

### Benefits

- Excellent resistance to chemical impact, humid conditions and environmental stress crack
- Long-lasting reliable solution – outstanding product lifetime of 15 years average
- Minimal watt losses thanks to orthocyclic winding process
- Control gear can be installed remotely

### Features

- Encapsulated with thermoplastic polyester resin, reinforced with glass fiber
- Equipped with screw terminal blocks as standard; insert contacts available upon request
- Ballasts for alternative mains voltages/frequencies available upon request
- Separate earth terminal (HID 'Heavy Duty')

### Application

- Outdoor lighting

# HID-HeavyDuty BSX for SOX

## Versions

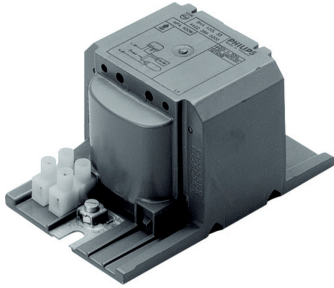

BSX 90 L40 230V 50Hz

## Dimensional drawing

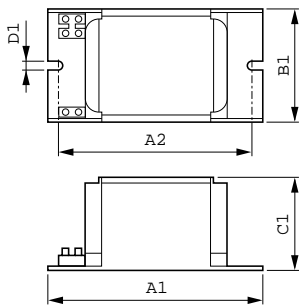

Product	D1	C1	A1	A2	B1
BSX 90 L40 230V 50Hz HD1-118	6.2 mm	53.0 mm	118.0 mm	103.0 mm	65.0 mm
BSX 90 L32 240V 50Hz HD1-118	6.2 mm	53.0 mm	118.0 mm	103.0 mm	65.0 mm

### Operating and Electrical

Input Frequency 50 Hz

### General Information

Number Of Lamps 1 piece/unit

Lamp Type SOX

### System characteristics

Rated Ballast-Lamp Power 90 W

## Operating and Electrical

Order Code	Full Product Name	Input Voltage
913650080426	BSX 90 L40 230V 50Hz HD1-118	230 V

Order Code	Full Product Name	Input Voltage
913650080526	BSX 90 L32 240V 50Hz HD1-118	240 V

## HID-HeavyDuty BSX for SOX

