



ProLux TPS550 C

TPS550 4XTL5-54W HFP MB

4 pcs - TL5 - 54 W - HF Performer - Medium beam

In industry, the bottom line is affected by a whole host of factors – worker productivity, running costs and maintenance, to name just a few. In today's economic environment, with margins under pressure, all businesses operating high-bay facilities are faced with the pressing need to save energy. Our ProLux high-bay solution is a direct replacement for current HID high-bay systems and enables significant energy savings. The combination of robust housing, high-reflectance material and specially designed reflector add up to a high-efficiency luminaire that can help drive profitability by improving energy efficiency.

Product data

General Information	
Number of light sources	4 [4 pcs]
Lamp family code	TL5 [TL5]
Lamp power	54 W
Gear	HFP [HF Performer]
Optic type	MB [Medium beam]
Connection	W3 [Plug-in connector 3-pole Wieland/Adels compatible (W)]

Operating and Electrical

Input voltage	220 to 240 V
---------------	--------------

Mechanical and Housing

Colour	White
--------	-------

Product Data	
Full product code	910403630502
Order product name	TPS550 4XTL5-54W HFP MB
EAN/UPC – product	8718291994398
Order code	910403630502
Numerator – quantity per pack	1
Numerator – packs per outer box	1
Material no. (12NC)	910403630502
Net weight (piece)	11.000 kg

ProLux TPS550 C

Dimensional drawing

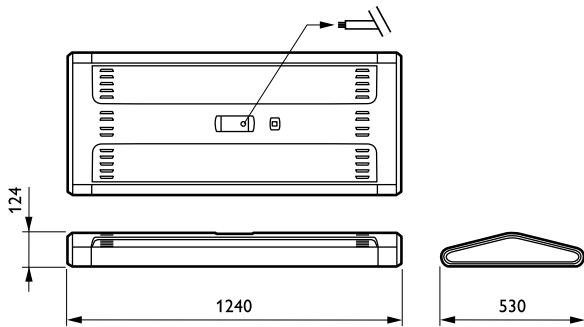

ProLux TPS550

