



Smart Track

ZCS170 1C LCP GR

3-circuit track - L-coupling piece 90°

Designed for operation in conjunction with the Smart Spot projector range, Smart Track is a one-phase track with enhanced earthing to ensure safety. This reliable and flexible solution offers a choice of colors, lengths and different-shaped couplers in order to meet challenging applications.

Product data

General Information	
Accessory color	Gray
Operating and Electrical	
Electrical accessories	L-coupling piece 90°
Circuit	3-circuit track
Mechanical and Housing	
Dimensions (Height x Width x Depth)	NaN x NaN x NaN mm (NaN x NaN x NaN in)
Product Data	
Full product code	911400894780

Order product name	ZCS170 1C LCP GR
EAN/UPC - Product	6923828688967
Order code	911400894780
Numerator - Quantity Per Pack	1
Numerator - Packs per outer box	50
Material Nr. (12NC)	911400894780
Net Weight (Piece)	0.120 kg

Smart Track

Dimensional drawing

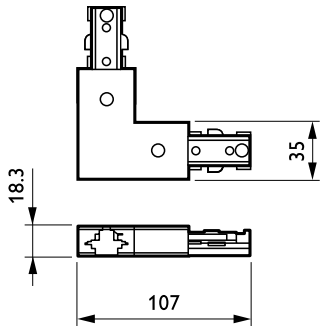

Smart Track acc. ZCS170

