



# Essential SmartBright LowBay

## BY088P LED20/WW

Essential SmartBright LowBay, 20 W, 1600 lm, 3000 K, 100°

Philips Essential SmartBright LowBay is a functional lighting by combining cost-efficiency with clean design. It offers customers all the benefits of LED lighting – reduced energy consumption, longer service time and less maintenance. Flexible, safe, and reliable, Essential SmartBright LowBay is a perfect LED replacement to conventional CFL LowBay system, allowing you to bright up your supermarkets, retail shops, and sports recreational spaces the smarter way.

### Product data

General Information		Operating and Electrical	
Light source replaceable	No	Correlated Color Temperature (Nom)	3000 K
Number of gear units	1 unit	Luminous Efficacy (rated) (Nom)	80 lm/W
Driver included	Yes	Color rendering index (CRI)	≥80
Light source engine type	LED	Light source color	830 warm white
Service tag	Yes	Optic type	Wide beam
CE mark	-	Optical cover type	Polycarbonate bowl/cover
Warranty period	1 years	Luminaire light beam spread	100°
Flammability mark	For mounting on normally flammable surfaces		
ENEC mark	-	Input Voltage	220–240 V
Glow-wire test	Temperature 650 °C, duration 5 s	Line Frequency	50 or 60 Hz
EU RoHS compliant	No	Inrush current	8.2 A
		Inrush time	30.8 ms
		Power Consumption	20 W
		Power Factor (Fraction)	0.9
		Connection	Flying leads/wires

## Essential SmartBright LowBay

Cable	Cable 0.3 m without plug
Number of products on MCB of 16 A type B 148	
<b>Temperature</b>	
Ambient temperature range	-20 to +40 °C
<b>Controls and Dimming</b>	
Dimmable	No
Driver/power unit/transformer	Power supply unit (On/Off)
Control interface	-
Constant light output	No
<b>Mechanical and Housing</b>	
Housing Material	Aluminum
Reflector material	Aluminum
Optic material	Polycarbonate
Optical cover material	Polycarbonate
Fixation material	-
Housing Color	Gray and black
Optical cover finish	Frosted
Overall height	133 mm
Overall diameter	250 mm
<b>Approval and Application</b>	
Ingress protection code	IP20 [Finger-protected]
Mech. impact protection code	IK03 [0.3 J]

Protection class IEC	Safety class I
<b>Initial Performance (IEC Compliant)</b>	
Luminous flux tolerance	+/-10%
Initial chromaticity	SDCM<5
Power consumption tolerance	+/-10%
<b>Over Time Performance (IEC Compliant)</b>	
Median useful life L70B50	15,000 hour(s)
<b>Application Conditions</b>	
Suitable for random switching	No
<b>Product Data</b>	
Order product name	BY088P LED20/WW
Full product name	BY088P LED20/WW
Full product code	692382862567200
Order code	911401668003
Material Nr. (12NC)	911401668003
Numerator - Quantity Per Pack	1
EAN/UPC - Product/Case	6923828625672
Numerator - Packs per outer box	1
EAN/UPC - Case	6923828625672

### Dimensional drawing

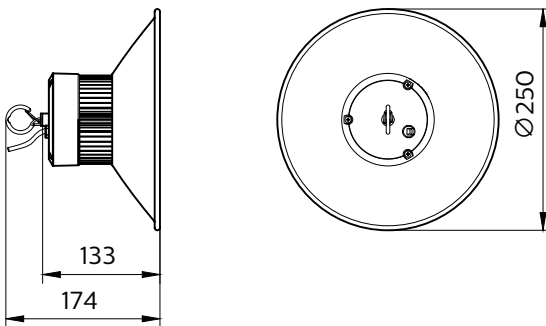

## Essential SmartBright LowBay

