



eW Graze MX Powercore

eW Graze MX Powercore, 3000 K, 60° x 30° Beam Angle, 1220 mm (4 ft)

eW Graze MX Powercore, 3000 K, 60° x 30° Beam Angle, 1220 mm (4 ft)

eW Graze MX Powercore is a high-performance, exterior linear luminaire that features the most light output in our line of solid white light grazing luminaires. It is designed to highlight architectural features ranging from surface textures and molding details to archways and windows. Graze Essential White luminaires offer a single channel of white light. Available in 2700 K, 3000 K, 3500 K, 4000 K, and 5500 K. Multiple luminaire lengths, beam angles, output levels, and power consumption levels support a large range of façade or surface illumination applications. Low-profile housing, connectorized cabling, a universal power input range, and direct line voltage operation make Graze luminaires easy to install and operate.

Product data

General information	
Lamp family code	LED-HB [LED High Brightness]
Light source color	White
Light source replaceable	No
Luminaire light beam spread	60° x 30°
Protection class IEC	Safety class I
CE mark	CE mark
UL mark	UL and cUL mark
Lifetime to 50% luminous flux	60000 h

Lifetime to 70% luminous flux	60000 h
Operating and electrical	
Input Voltage	100 to 277 V
Input Frequency	50 to 60 Hz
Controls and dimming	
Dimmable	Yes

eW Graze MX Powercore

Mechanical and housing

Housing Material	Aluminum extruded
Optical cover/lens material	Polycarbonate
Length	1219 mm

Approval and application

Ingress protection code	IP66 [Dust penetration-protected, jet-proof]
Mech. impact protection code	IK10 [20 J vandal-resistant]
Vibration Standard	Not compliant to ANSI C136.31, 3G. Special orders are available to conform to the standard. Please contact your Color Kinetics Lighting Sales rep for custom configurations.
Corrosion Resistance	Complies with ASTM B117 standard with special order. Please contact your Color Kinetics Lighting Sales rep for custom configurations.
FCC mark	FCC Class A
Vibration Rating	Not compliant to ANSI C136.31, 3G. Special orders are available to conform to the standard. Please contact your Color Kinetics Lighting Sales rep for custom configurations.

Initial performance (IEC compliant)

Init. Corr. Color Temperature	3000 K
Initial input power	60 W

Over time performance (IEC compliant)

Lumen Maintenance 50% at 25°C	60000
Reported	

Lumen Maintenance 50% at 50°C	60000
Reported	
Lumen Maintenance 70% at 25°C	60000
Reported	
Lumen Maintenance 70% at 50°C	60000
Reported	

Application conditions

Ambient temperature range	-20 to +50 °C
---------------------------	---------------

Product data

Full product code	871829139588100
Order product name	BCS419 60x30 -3000 L1219
EAN/UPC - Product	8718291395881
Order code	523-000080-79
Numerator - Quantity Per Pack	1
Numerator - Packs per outer box	1
Material Nr. (12NC)	912400135132
Net Weight (Piece)	4.700 kg
Catalog Number	523-000080-79
Catalog Number Description	eW Graze MX Powercore, 3000 K, 60° x 30° Beam Angle, 1220 mm (4 ft)



Dimensional drawing

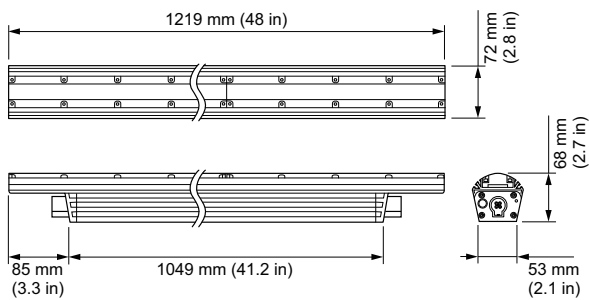

BCS419 60x30 -3000 L1219

