

HID-Basic BSX for SOX

BSX 35/55 L82 240V 50Hz WITH BRACKET

Impregnated electromagnetic copper/iron ballasts for use with an external ignitor for SOX and SOX-E lamps

Product data

General Information	
Application Code	L82
Design	WITH BRACKET
Lamp Type	SOX
Number of Lamps	1 piece/unit
Operating and Electrical	
Input Voltage	240 V
Input Frequency	50 Hz
Mains Voltage Performance (AC)	-8% - +6%
Mains Voltage Safety (AC)	-10% - +10%
Input Current with PF Correction	0.22 A
Input Current without PF Correction	0.60 A
Power Factor without PF Compensation (Nom)	0.35
Power Losses (Nom)	12.0 W
Wiring	
Wire Striplength	8.0-1.0 mm
Ballast Contact Wire Cross Section	0.70-1.50 mm ²
Connector Type	Insert

System characteristics	
Capacitor	5.7µF/450V
Rated Ballast-Lamp Power	35/55
Recommended Ignitor	ignitor SX72 (913654059066)
Temperature	
T-Storage (Max)	80 °C
T-Storage (Min)	-25 °C
T-Winding (Max)	130 °C
Delta-T Normal Conditions	65 °C
Approval and Application	
Approval Marks	CE marking ENEC certificate
Product Data	
Full product code	872790090500700
Order product name	BSX 35/55 L82 240V 50Hz WITH BRACKET
EAN/UPC - Product	8711500999221
Order code	913700279926
Numerator - Quantity Per Pack	1
Numerator - Packs per outer box	15

HID-Basic BSX for SOX

Material Nr. (12NC)	913700279926
Net Weight (Piece)	1.045 kg

Dimensional drawing

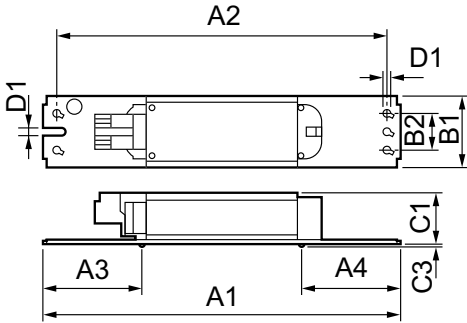

BSX 35/55 L82 240V 50Hz WITH BRACKET

Product	D1	C1	C3	A1	A2	A3	A4	B1	B2
BSX 35/55 L82	4.2	28.0	1.5	196.0	180.0	54.0	54.0	39.0	20.0
240V 50Hz	mm	mm	mm	mm	mm	mm	mm	mm	mm
WITH BRACKET									

