

PHILIPS

Lighting



HF-Regulator II for TL-D lamps

HF-R 236 TL-D EII 220-240V 50/60Hz

High-frequency electronic dimming ballast, using the analog protocol (1-10 V) for TL-D lamps

Product data

General Information

Application code	EII
Type version	mk2
Lamp type	TL-D
Number of lamps	2 piece/unit
Number of products on MCB (16 A type B) (nom.)	12
Automatic restart	Yes

Operating and Electrical

Input voltage	220 to 240 V
Input frequency	50 to 60 Hz
Operating frequency (max.)	89 kHz
Operating frequency (min.)	45 kHz
Ignition method	Programmed Start
Crest factor (max.)	1.7
Power factor 100% load (nom.)	0.98
Ignition time (max.)	0.2 s
Mains voltage performance (AC)	-8%~+6%
Mains voltage safety (AC)	-10%~+10%
Earth leakage current (max.)	0.5 mA
Inrush current width	0.40 ms

Power losses (nom.)	7.3 W
Inrush current peak (max.)	45 A

Wiring

Connector type input terminals	WAGO 251 universal connector [Suitable for both automatic wiring (ALF and ADS) and manual wiring]
Connector type output terminals	WAGO 251 universal connector [Suitable for both automatic wiring (ALF and ADS) and manual wiring]
Connector type control input terminals	WAGO 251 universal connector [Suitable for both automatic wiring (ALF and ADS) and manual wiring]
Wire strip length	8.0-9.0 mm
Dual fixture master/slave	- [not specified]
Control input terminal cross section	0.50-1.00 mm ²
Input terminal cross section	0.50-1.00 mm ²
Output terminal cross section	0.50-1.00 mm ²
Auto Insert (ALF/ADS) Wire Cross Section	0.5 mm ²

System characteristics

Rated ballast-lamp power	36 W
--------------------------	------

HF-Regulator II for TL-D lamps

Temperature	
T ambient (max.)	50 °C
T ambient (min.)	10 °C
T storage (max.)	80 °C
T storage (min.)	-25 °C
Stable lamp operation temperature	Not Specified
T-Ignition (max.)	50 °C
T-Ignition (min.)	0 °C

Controls and Dimming	
Control interface	1-10V
Regulating level power	1%-100%
Control input protection	Yes (Basic insulation)

Mechanical and Housing	
Housing	L 360x30x21

Emergency Operation	
Battery voltage lamp ignition	196 V
Battery voltage lamp operation	154-276

Approval and Application	
Energy efficiency index	A1 BAT
IP classification	IP 20 [Ingress Protection 20]
EMI 9 kHz... 30 MHz	EN55015
EMI 30 MHz... 1,000 MHz	EN55022 level B

Safety standard	IEC 61347-2-3
Performance standard	IEC 60929
Quality standard	ISO 9000:2000
Environmental standard	ISO 14001
Harmonic current emission standard	IEC 61000-3-2
EMC immunity standard	IEC 61547
Vibration standard	IEC68-2-6 F c
Bumps standard	IEC 68-2-29 Eb
Humidity standard	EN 61347-2-3 clause 11
Approval marks	CE marking ENEC certificate VDE-EMV certificate
Temperature marking	Yes
Emergency standard	IEC 60598-2-22
Humming and noise level	Inaudible

Product Data	
Full product code	871150091015830
Order product name	HF-R 236 TL-D EII 220-240V 50/60Hz
EAN/UPC – product	8711500910158
Order code	91015830
Numerator – quantity per pack	1
Numerator – packs per outer box	12
Material no. (12NC)	913700609366
Net weight (piece)	0.295 kg

Dimensional drawing

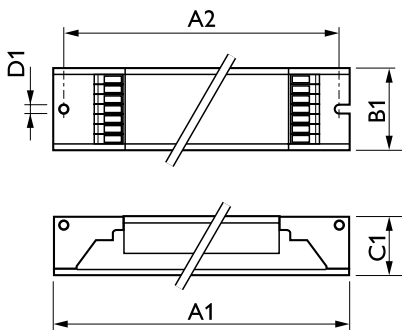

HF-R 236 TL-D EII 220-240V 50/60Hz

Product	D1	C1	A1	A2	B1
HF-R 236 TL-D EII 220-240V 50/60Hz	4.2 mm	22 mm	360 mm	350 mm	30 mm

HF-Regulator II for TL-D lamps

