



PrimaVision Compact for CDM

HID-PV C 70 /S CDM 220-240V 50/60Hz NG

High-quality, compact and lightweight HID electronic gear for optimal and reliable performance of 20, 35, 50 and 70 W CDM lamps

Product data

General Information		Inrush Current Peak (Max)	
Type Version	ng		33 A
Lamp Type	CDM	Wiring	
Number of Lamps	1 piece/unit	Cable Capacity Output Wires Mutual (Nom)	100 pF
Suitable For Outdoor Use	No	Cable Length From Device to Lamp	1.5 m
Number of Products on MCB (16A Type B) (Nom)	20	Ballast Contact Wire Cross Section	0.50-2.50 mm ²
Automatic Restart	Yes	Connector Type	Insert
Operating and Electrical		System characteristics	
Input Voltage	220 to 240 V	Rated Ballast-Lamp Power	70 W
Input Frequency	50 to 60 Hz	Temperature	
Operating Frequency (Nom)	0.14 kHz	T-Ambient (Max)	50 °C
Power Factor 100% Load (Nom)	0.95	T-Ambient (Min)	-20 °C
Ignition Voltage (Max)	4.0 kV	T-Storage (Max)	80 °C
Ignition Switch-Off Time (Nom)	18 min	T-Storage (Min)	-25 °C
Mains Voltage Performance (AC)	-10%+6%	T-Case Lifetime (Nom)	80 °C
Mains Voltage Safety (AC)	-18%+10%	T-Case Maximum (Max)	80 °C
Inrush Current Width	0.33 ms	Mechanical and Housing	
Constant Wattage Deviation	-3%/+3%	Housing	/S
Power Losses (Nom)	7.0 W		

PrimaVision Compact for CDM

Approval and Application

Active Temperature Protection	Yes
EMI 9 kHz ... 300 MHz	CISPR 15 ed 7.2
Safety Standard	EN 61347-2-12
Quality Standard	ISO 9000:2000
Environmental Standard	ISO 14001
Harmonic Current Emission Standard	EN 61000-3-2
EMC Immunity Standard	EN 61547
Vibration Standard	IEC68-2-6 F c
Bumps Standard	IEC 68-2-29 Eb
Humidity Standard	IEC 928-13
Approval Marks	CE marking ENEC certificate
Hum And Noise Level	37 dB(A)

Product Data

Full product code	872790085974400
Order product name	HID-PV C 70 /S CDM 220-240V 50/60Hz NG
EAN/UPC - Product	8711500881694
Order code	913700652966
Numerator - Quantity Per Pack	1
Numerator - Packs per outer box	12
Material Nr. (12NC)	913700652966
Net Weight (Piece)	0.216 kg

Dimensional drawing

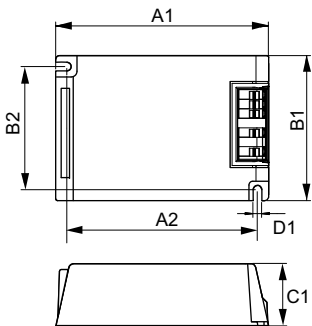

HID-PV C 70 /S CDM 220-240V 50/60Hz NG

Product	D1	C1	A1	A2	B1	B2
HID-PV C 70 /S CDM 220-240V 50/60Hz NG	4.9 mm	32.2 mm	109.6 mm	98.5 mm	74.4 mm	63.7 mm

