

PrimaVision Compact for CDM

HID-PV C 50 /S CDM 220-240V 50/60Hz

High-quality, compact and lightweight HID electronic gear for optimal and reliable performance of 20, 35, 50 and 70 W CDM lamps

Product data

General Information	
Lamp Type	CDM
Number of Lamps	1 piece/unit
Suitable For Outdoor Use	No
Number of Products on MCB (16A Type B) (Nom)	24
Automatic Restart	Yes
Operating and Electrical	
Input Voltage	220 to 240 V
Input Frequency	50 to 60 Hz
Operating Frequency (Nom)	0.14 kHz
Power Factor 100% Load (Nom)	0.95
Ignition Voltage (Max)	4.0 kV
Ignition Switch-Off Time (Nom)	18 min
Mains Voltage Performance (AC)	-10%~+6%
Mains Voltage Safety (AC)	-18%~+10%
Earth Leakage Current (Max)	0.25 mA
Inrush Current Width	0.25 ms
Constant Wattage Deviation	-3%/+3%
Power Losses (Nom)	6 W

Inrush Current Peak (Max)	26 A
Wiring	
Cable Capacity Output Wires Mutual (Nom)	150 pF
Cable Length From Device to Lamp	1.5 m
Wire Striplength	10.0-11.0 mm
Ballast Contact Wire Cross Section	0.50-2.50 mm ²
Connector Type	Insert

System characteristics	
Rated Ballast-Lamp Power	50 W
Temperature	
T-Ambient (Max)	55 °C
T-Ambient (Min)	-20 °C
T-Storage (Max)	80 °C
T-Storage (Min)	-25 °C
T-Case Lifetime (Nom)	80 °C
T-Case Maximum (Max)	80 °C

PrimaVision Compact for CDM

Mechanical and Housing	
Housing	/S

Approval and Application	
IP Classification	20
Active Temperature Protection	Yes
EMI 9 kHz ... 300 MHz	CISPR 15 ed 7.2
Safety Standard	IEC 61347-2-3
Quality Standard	ISO 9000:2000
Environmental Standard	ISO 14001
Harmonic Current Emission Standard	IEC 61000-3-2
EMC Immunity Standard	IEC 61547
Vibration Standard	IEC68-2-6 F c
Bumps Standard	IEC 68-2-29 Eb
Humidity Standard	IEC 928-13

Approval Marks	CE marking ENEC certificate
Hum And Noise Level	37 dB(A)

Product Data	
Full product code	872790093363500
Order product name	HID-PV C 50 /S CDM 220-240V 50/60Hz
EAN/UPC - Product	8727900933635
Order code	913700664966
Numerator - Quantity Per Pack	1
Numerator - Packs per outer box	12
Material Nr. (12NC)	913700664966
Net Weight (Piece)	0.240 kg

Dimensional drawing

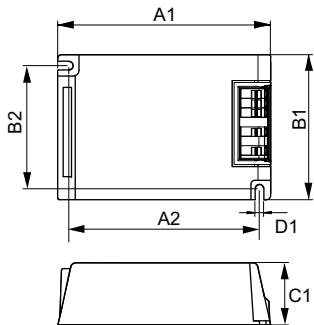

HID-PV C 50 /S CDM 220-240V 50/60Hz

Product	D1	C1	A1	A2	B1
HID-PV C 50 /S CDM 220-240V 50/60Hz	4.9 mm	32.2 mm	109.6 mm	98.5 mm	74.4 mm

