



Dynalite Sensors

DUS360CS

The Philips Dynalite sensor range combines motion detection, light level detection and IR receive in one unit. Each of these features can be operated at the same time, allowing automation scenarios such as turning on the lights after detecting motion and then dimming the lighting level once the available sunlight has been measured, thereby providing additional energy savings. By combining each of these functions into one device, operational efficiency is improved. Each sensor has an in-built microprocessor, allowing logical functions to control one small room, the floor of a building, or an entire building. All sensors receive their power from the DyNet network, and as they are fully remotely programmable, they can be configured to automate and control a virtually unlimited number of controlled outputs.

The Philips Dynalite sensor range combines motion detection, light level detection and IR receive in one unit. Each of these features can be operated at the same time, allowing automation scenarios such as turning on the lights after detecting motion and then dimming the lighting level once the available sunlight has been measured, thereby providing additional energy savings. By combining each of these functions into one device, operational efficiency is improved. Each sensor has an in-built microprocessor, allowing logical functions to control one small room, the floor of a building, or an entire building. All sensors receive their power from the DyNet network, and as they are fully remotely programmable, they can be configured to automate and control a virtually unlimited number of controlled outputs.

Product data

Dynalite Sensors

General Information

Remarks Please download the Lighting - Product Data Sheet for more information and ordering options

Product Family Code YSENSO [Sensors]

Product Data

Full product code 871869688796700

Order product name DUS360CS

EAN/UPC – product 8718696887967

Order code 88796700

Numerator – quantity per pack 1

Numerator – packs per outer box 1

Material no. (12NC) 913703243109

Net weight (piece) 0.220 kg

Dimensional drawing

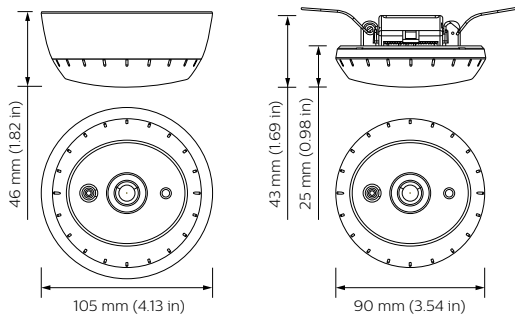

Dynalite Sensors

