



Dynalite Sensors

DUS360CR-DA

Low profile 360° ceiling sensor - DIP Switch

Low profile 360° ceiling sensor - DIP Switch

Product data

General Information	
Remarks	Please download the Lighting - Product Data Sheet for more information and ordering options
RoHS mark	RoHS mark
Approval and Application	
UL Recognized Canada & US	Yes
Product Data	
Full product code	871869688641000

Order product name	DUS360CR-DA
EAN/UPC - Product	8718696886410
Order code	88641000
Numerator - Quantity Per Pack	1
Numerator - Packs per outer box	1
Material Nr. (12NC)	913703500809
Net Weight (Piece)	95.000 g

Dynalite Sensors

Dimensional drawing

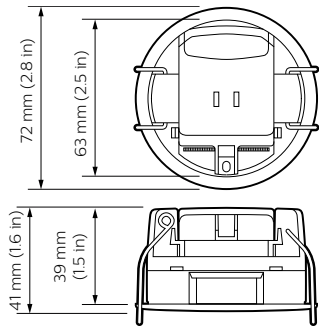

Dynalite Sensors

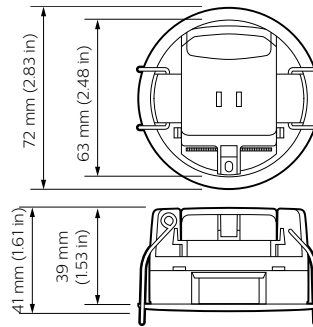

Dynalite Sensors

