



HID-CertaVision for CDM

HID-CV 150 /S CDM 220-240 50/60Hz

HID-CertaVision electronic ballast for use with ceramic metal-halide (CDM) lamps

Product data

Operating and Electrical	
Input Voltage	220 to 240 V
Line Frequency	50 to 60 Hz
Input Frequency	50 to 60 Hz
Inrush Current Width	0.60 ms
Inrush Current Peak (Nom)	55 A
Number of Products on MCB (16A Type B) (Nom)	24
Wiring	
Cable Length From Device to Lamp	1.5 m
Connector Type	Push
Temperature	
Ambient temperature range	-20 °C to 55 °C
T-Case Lifetime (Nom)	85 °C
T-Case Maximum (Max)	85 °C

Mechanical and Housing	
Housing	/S
Approval and Application	
Approval Marks	F-Marking CE marking ENEC certificate
Product Data	
Order product name	HID-CV 150 /S CDM 220-240 50/60Hz
Full product name	HID-CV 150 /S CDM 220-240 50/60Hz
Full product code	694793917414000
Order code	913712003813
Material Nr. (12NC)	913712003813
Numerator - Quantity Per Pack	1
EAN/UPC - Product/Case	6947939174140
Numerator - Packs per outer box	12
EAN/UPC - Case	6947939174157

HID-CertaVision for CDM

Dimensional drawing

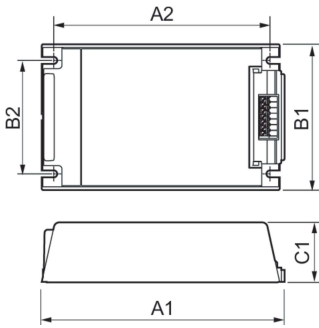

Product	C1	A1	A2	B1	B2	B3
HID-CV 150 /S CDM 220-240 50/60Hz	38.0 mm	150.0 mm	133.6 mm	90.0 mm	70.0 mm	4.3 mm

