



HF-Performer III for TL5 lamps

HF-P 280 TL5/PL-L III 220-240V 50/60Hz

HF-Performer III TL5 is a sustainable, slim and high-frequency electronic ballast for TL5 and TL5 Eco fluorescent lamps. It is ideal for applications where high energy efficiency is required. The HF-Performer III range has a robust design, meets all relevant international safety and performance standards and is energy-efficient (CELMA EEI A2 BAT).

Product data

General Information	
Application code	III
Type version	mk1
Lamp type	TL5/PL-L
Number of lamps	2 piece/unit
Number of products on MCB (16 A type B) (nom.)	8
Automatic restart	Yes
Operating and Electrical	
Input voltage	220 to 240 V
Input frequency	50 to 60 Hz
Operating frequency (nom.)	45 kHz
Ignition method	Warm Start
Crest factor (max.)	1.7
Power factor 100% load (nom.)	0.99
Ignition time (max.)	0.9 s
Mains voltage performance (AC)	-8%+6%
Mains voltage safety (AC)	-10%+10%
Earth leakage current (nom.)	0.5 mA

Inrush current width	0.38 ms
Constant wattage deviation	-2%/+2%
Ballast factor (nom.)	1.04
Power losses (nom.)	9-10 W
Inrush current peak (max.)	35 A
Wiring	
Connector type input terminals	WAGO 251 universal connector [Suitable for both automatic wiring (ALF and ADS) and manual wiring]
Cable capacity output wires mutual (nom.)	200 pF
Connector type output terminals	WAGO 251 universal connector [Suitable for both automatic wiring (ALF and ADS) and manual wiring]
Cable length hot-wiring	0.75 m
Wire strip length	8.0-9.0 mm
Dual fixture master/slave	Not applicable [Master/Slave oper. not applicable]
Input terminal cross section	0.50-1.00 mm ²
Output terminal cross section	0.50-1.00 mm ²

HF-Performer III for TL5 lamps

Cable capacity output wires to earth (nom.)	200 pF
---	--------

System characteristics

Rated ballast-lamp power	80 W
Rated lamp power on PL-L	80 W
System power on PL-L	87.5 W
Lamp power on PL-L	80 W
Power loss on PL-L	7.5 W
Rated lamp power on TL5	80 W
System power on TL5	89.6 W
Lamp power on TL5	80 W
Power loss on TL5	9.6 W

Temperature

T ambient (max.)	60 °C
T ambient (min.)	-25 °C
T storage (max.)	50 °C
T storage (min.)	-40 °C
T case lifetime (nom.)	85 °C
T-Case maximum (max.)	85 °C
T-Ignition (max.)	60 °C
T-Ignition (min.)	-25 °C

Mechanical and Housing

Housing	L 425x30x21
---------	-------------

Emergency Operation

Nominal light output after 60 seconds	100% of EBLF
Battery voltage lamp ignition	186-275 V
Normal operating voltage (DC)	220-240 V
Battery voltage lamp operation	176-275
Battery voltage guaranteed operation	176-275 V
Battery voltage guaranteed ignition	186-275 V
Emergency ballast lumen factor (EBLF) (nom.)	100 %

Nominal light output after 5 seconds	50% of EBLF
--------------------------------------	-------------

Approval and Application

Energy efficiency index	A2 BAT
IP classification	IP 20 [Ingress Protection 20]
EMI 9 kHz... 30 MHz	EN 55015 edition 7.1
EMI 30 MHz... 1,000 MHz	EN55022 level B
Safety standard	IEC 61347-2-3
Performance standard	IEC 60929
Quality standard	ISO 9000:2000
Environmental standard	ISO 14001
Harmonic current emission standard	IEC 61000-3-2
EMC immunity standard	IEC 61547
Vibration standard	IEC68-2-6 F c
Bumps standard	IEC 68-2-29 Eb
Humidity standard	EN 61347-2-3 clause 11
Approval marks	CE marking ENEC certificate VDE-EMV certificate
Temperature marking	Yes
Emergency standard	IEC 60598-2-22
Humming and noise level	< 30 dB(A)

Product Data

Full product code	872790095230800
Order product name	HF-P 280 TL5/PL-L III 220-240V 50/60Hz
EAN/UPC – product	8727900952308
Order code	95230800
Local Code	HFP280T5PLLEIII
Numerator – quantity per pack	1
Numerator – packs per outer box	12
Material no. (12NC)	913713034366
Net weight (piece)	0.360 kg

Dimensional drawing

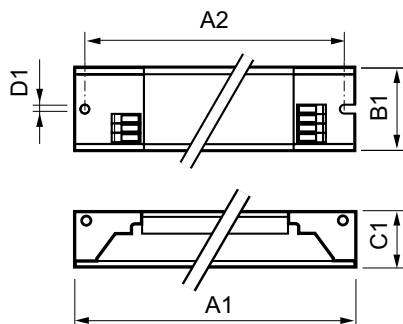

HF-P 280 TL5/PL-L III 220-240V 50/60Hz

Product	D1	C1	A1	A2	B1
HF-P 280 TL5/PL-L III 220-240V 50/60Hz	4.2 mm	21.0 mm	425.0 mm	415.0 mm	30.0 mm

HF-Performer III for TL5 lamps

