



# LED AR111

## 12AR111/LED/930/S8 DIM 12V FB 1PK 6/1

With an elegant new design, Philips MasterClass LED AR111 creates a brilliant visual effect. With excellent rendering of 90+ CRI and R9>50, colors stay vibrant and natural, enhancing the appeal of everything on display.

### Product data

General Information	
Base	G53 [ G53]
Nominal Lifetime (Nom)	40000 h
Switching Cycle	50000X
Technical Type	11-50W
Light Technical	
Color Code	930 [ CCT of 3000K]
Beam Angle (Nom)	8 °
Initial lumen (Nom)	610 lm
Luminous Intensity (Nom)	8000 cd
Color Designation	White (WH)
Rated Beam Angle	8 °
Correlated Color Temperature (Nom)	3000 K
Luminous Efficacy (rated) (Nom)	50.83 lm/W
Color Consistency	<6
Color Rendering Index (Nom)	90
LLMF At End Of Nominal Lifetime (Nom)	70 %
Luminous Flux in 90° Cone (Rated)	610 lm
Operating and Electrical	
Power (Rated) (Nom)	11 W
Lamp Current (Nom)	1300 mA
Wattage Equivalent	50 W

Starting Time (Nom)	0.5 s
Warm Up Time to 60% Light (Nom)	0.5 s
Power Factor (Nom)	0.7
Voltage (Nom)	12 V
Temperature	
T-Case Maximum (Nom)	65 °C
Controls and Dimming	
Dimmable	Yes
Approval and Application	
Energy Efficiency Label (EEL)	Not applicable
Energy Saving Product	Yes
Suitable For Accent Lighting	Yes
Energy Consumption kWh/1000 h	- kWh
Product Data	
Order product name	12AR111/LED/930/S8 DIM 12V FB 1PK 6/1
EAN/UPC - Product	046677463786
Order code	463786
Numerator - Quantity Per Pack	1
Numerator - Packs per outer box	6
Material Nr. (12NC)	929001244004

# LED AR111

Net Weight (Piece) 0.160 kg

## Dimensional drawing

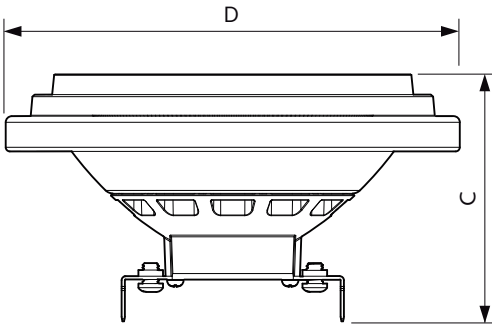

AR111 Silver 11W-50W 620lm 8D 3000K G53D

Product	D	C
12AR111/LED/930/S8 DIM 12V FB 1PK 6/1	111 mm	62 mm

## Photometric data

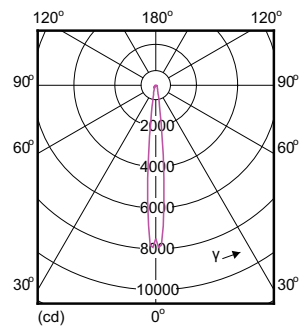
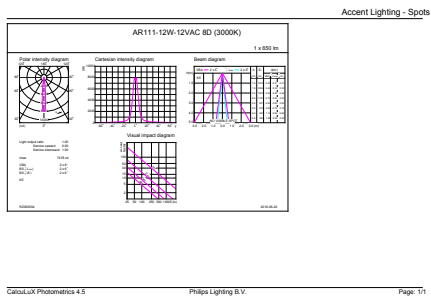

LED Lamps, MAS LEDspotLV D 11-50W AR111 G53 830 8D

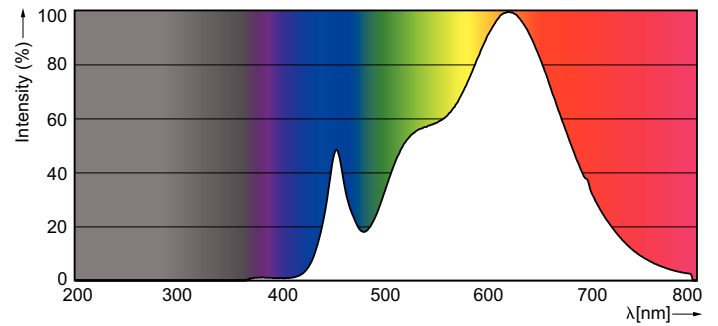

11-50W AR111 /930

# LED AR111

## Lifetime

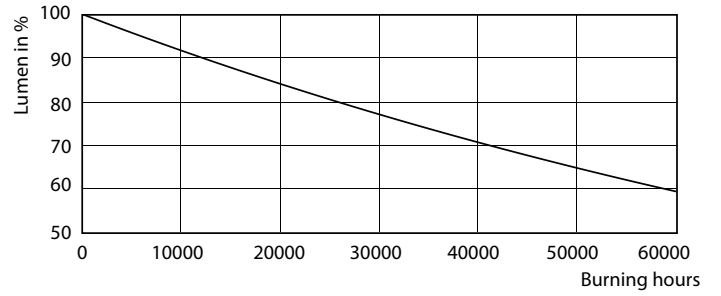
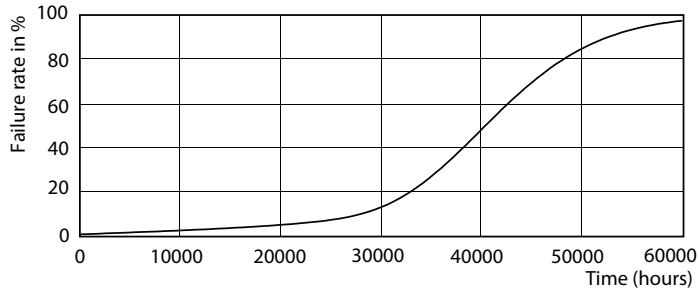

MASTER LEDspotLV AR111 75W G53 940 40D

MASTER LEDspotLV AR111 75W G53 940 40D

