



LED MR16

7MR16 ExpertColor Retail S10 930 10/1

Philips LED MR-16 lamps with single optic technology provide the look and color quality of traditional halogens while using a fraction of the energy. A perfect fit for spot lighting, they are compatible with most existing fixtures with MR16 GU5.3 holders and are designed as a retrofit replacement for halogen or incandescent spots.

Product data

General Information	
Cap-Base	GU5.3 [GU5.3]
Nominal Lifetime (Nom)	40000 h
Switching Cycle	50000X
Technical Type	7-30W
Light Technical	
Color Code	930 [CCT of 3000K]
Beam Angle (Nom)	10 °
Luminous Flux (Nom)	430 lm
Luminous Flux (Rated) (Nom)	430 lm
Luminous Intensity (Nom)	4600 cd
Color Designation	White (WH)
Rated Beam Angle	10 °
Correlated Color Temperature (Nom)	3000 K
Luminous Efficacy (rated) (Nom)	61.43 lm/W
Color Consistency	<3
Color Rendering Index (Nom)	90
LLMF At End Of Nominal Lifetime (Nom)	70 %
Operating and Electrical	
Power (Rated) (Nom)	7 W

Lamp Current (Nom)	800 mA
Starting Time (Nom)	0.5 s
Warm Up Time to 60% Light (Nom)	0.5 s
Power Factor (Nom)	0.7
Voltage (Nom)	12 V
Temperature	
T-Case Maximum (Nom)	90 °C
Controls and Dimming	
Dimmable	No
Approval and Application	
Suitable For Accent Lighting	Yes
Product Data	
Order product name	7MR16 ExpertColor Retail S10 930 10/1
EAN/UPC - Product	046677470227
Order code	470229
Numerator - Quantity Per Pack	1
Numerator - Packs per outer box	10
Material Nr. (12NC)	929001342604

LED MR16

Net Weight (Piece) 0.034 kg

Dimensional drawing

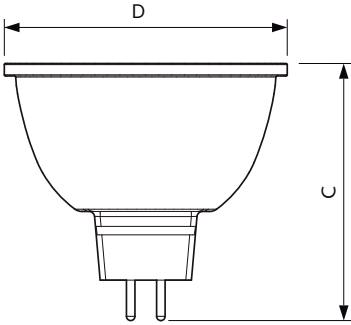

MR16 12V 6.5-30W 10D 3000K GU5.3 ND

Product	D	C
7MR16 ExpertColor Retail S10 930 10/1	51 mm	46 mm

Photometric data

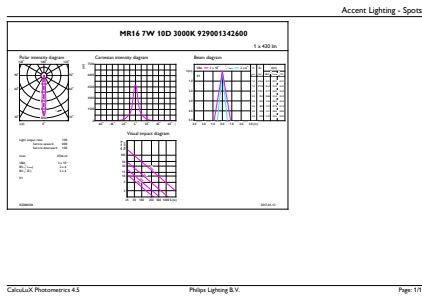

MR16 12V 6.5-30W 10D 3000K GU5.3 ND

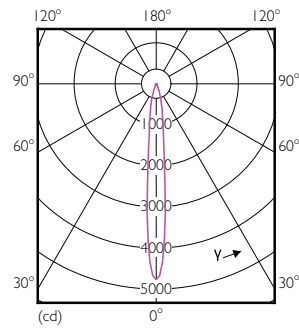

LEDspots MR16 7W 930 430lm 10D

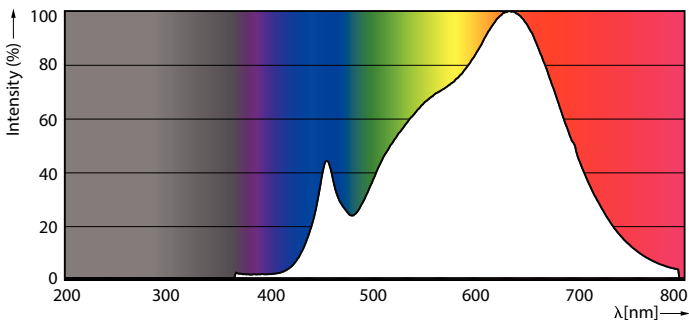

LEDspots MR16 7W 3000K

LED MR16

Lifetime

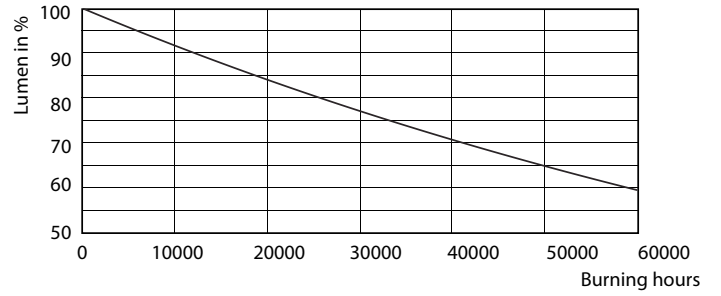
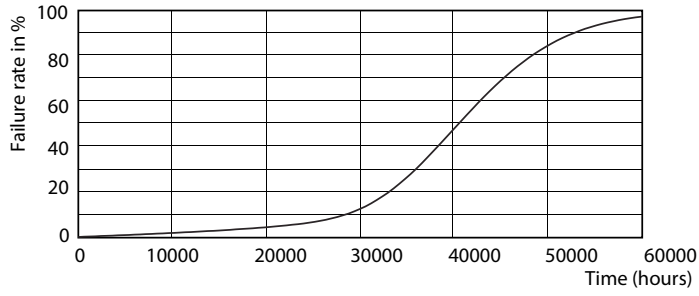

LEDspots MR16 7W

LEDspots MR16 7W

